

ULTRAFLOW®

Ultrasonic flow meter

Compact design

Static meter with no moving parts

Large dynamic range

No wear

Exceptionally accurate

Longevity



TS 27.01 113 TS 27.01 109
OIML R75 DS/EN 1434

Application

ULTRAFLOW® TYPE 65-S/R is a static flow meter based on the ultrasonic measuring principle. The prime area of application is as a volume flow meter for use with thermal heat meters such as MULTICAL® and MAXICAL. ULTRAFLOW® is designed for use in heating installations where water is used as the heat-bearing medium.

ULTRAFLOW® employs micro-processor technology and ultrasonic measuring techniques. All circuits for calculating and measuring are collected on a single board, providing compact and rational design in addition to an exceptionally high level of measuring accuracy and reliability.

The flow is measured using bidirectional ultrasonic technique based on the transit time method, with proven long-term stability and accuracy. Two ultrasonic transducers are used to send the sound signal both against and with the flow direction. The ultrasonic signal travelling with the flow direction reaches the opposi-

te transducer first. The time difference between the two signals can be converted to a flow velocity and thus a volume.

A multiplug, placed beneath the seal, is used during communication and calibration.

A three-wire pulse cable is used to connect ULTRAFLOW® to the calculator. This cable is used to supply the flow meter from the calculator and also to send the signal to the calculator. The signal corresponds to the flow, or more correctly, a number of pulses proportional to the water volume flowing through the meter is transmitted.

If required a pulse transmitter can be used to supply ULTRAFLOW®, e.g. if the distance between MULTICAL® and ULTRAFLOW® is 10 m or more. The pulse transmitter has a built-in supply and a galvanically separated pulse outlet.

Approvals

TYPE APPROVAL

ULTRAFLOW® Types 65-S and 65-R are approved by EFS in accordance with EN1434 and OIML R75.

The test report -project K286128 - forms the basis for type approval in a number of countries, including Denmark.

TS 27.01
113

TS 27.01
109

OIML R75 DS/EN 1434

Please contact Kamstrup A/S for further information relating to type approval and verification.

CE-MARKING

ULTRAFLOW® Types 65-S and 65-R are marked in accordance with the EMC and LV directives.

Technical data

MECHANICAL DATA

Metrological class	2 and 3
Environmental class	Complies with DS/EN 1434 class C
Ambient temperature	0...55°C
Protection class	
$q_p \leq 40 \text{ m}^3/\text{h}$	IP56
$q_p \geq 60 \text{ m}^3/\text{h}$	IP55
Pulse transmitter	IP54
Temperature* of medium	15...130°C
Storage temp. drained meter	-25...70°C, 60°C with fitted/supplied battery
Pressure stage	PN16, PN25 flange
Time constant	6 s, fast response meter

* If the temperature of the medium exceeds 90°C a flange meter should be used. Additionally, MULTICAL® calculator or the pulse transmitter should be wall-mounted.

ELECTRICAL DATA

Supply voltage	3.6 V ±10%
Battery (pulse transmitter)	3.65 VDC, D-Cell lithium
Replacement interval	10 years @ $t_{BAT} < 35^\circ\text{C}$
Power supply (pulse transmitter)	230 VAC +15/-30%, 48...52 Hz 24 VAC/DC ±30%
Back-up supply	Integral super-cap eliminates operational disturbances due to short-term power-cuts.
Cable length, flow meter	Max. 10 m
Cable length (pulse transmitter)	Depends on calculator
EMC data	Complies with DS/EN 1434 class C

FLOW DATA

Nom. flow q_p [m³/h]	Nom. diameter [mm]	Meter factor ¹⁾ [pulse/l]	Dynamic range $q_s:q_p$	$q_s:q_p$	Flow@125 Hz ²⁾ [m³/h]	Δp [bar]	Min. cut off [l/h]
0.6	DN15 & DN20	300	1:100	2:1	1.5	0.04	2
1.5	DN15 & DN20	100	1:100	2:1	4.5	0.23	3
3	DN20	50	1:100	2:1	9	0.04	6
3.5	DN25	50	1:100	2:1	9	0.06	7
6	DN25	25	1:100	2:1	18	0.16	12
10	DN40	15, 25	1:100	2:1, 1.8:1	30, 18	0.07	20
15	DN50	10	1:100	2:1	45	0.15	30
25	DN65	6, 10	1:100	2:1, 1.8:1	75, 45	0.08	50
40	DN80	5	1:100	2:1	90	0.2	80
60	DN100	2.5	1:100	2:1	180	0.15	120
150	DN150	1	1:100	2:1	450	0.025	300
400	DN150	0.4	1:100	2:1	1125	0.18	800
400	DN250	0.4	1:100	2:1	1125	0.015	800
1000 ³⁾	DN250	0.25	1:100	1.8:1	1800	0.01	2000

¹⁾ The meter factor can be seen on the label on the side of the meter.

²⁾ Saturation flow. Max. pulse frequency 128 Hz is maintained at higher flow rates.

³⁾ q_p 1000 m³/h is not included in the Danish approval.

Materials

WETTED PARTS

ULTRAFLOW®, q_p 0.6 og 1.5 m³/h

Housing	Enkotal (alpha brass)
Transducers	AISI 316 (W. No. 1.4401)
Gaskets	EPDM
Reflectors	PES 30% GF and AISI 304 (W. No. 1.4301)
Measuring pipe	PES 30% GF

ULTRAFLOW®, q_p 3 to 40 m³/h

Housing, gland	Enkotal (alpha brass)
Housing, flange	RG5204 (red brass)
Transducers	AISI 316 (W. No. 1.4401)
Gaskets	EPDM
Measuring	PES 30% GF
Reflectors	AISI 304 (W. No. 1.4301)

ULTRAFLOW®, q_p 60 m³/h

Housing	GGG40.3 (spherical cast iron)
Transducers	AISI 316 (W. No. 1.4401)
Gaskets	Viton
Measuring pipe	PPS 30% GF
Reflectors	AISI 304 (W. No. 1.4301)

ULTRAFLOW®, q_p 150 til 1000 m³/h

Housing	GGG40.3 (spherical cast iron)
Transducers	AISI 316 (W. No. 1.4401)
Gaskets	Viton
Measuring pipe	Integral part of the housing

ELECTRONIC HOUSING

Base	PBT 30% GF
Lid	PC 30% GF

CONNECTION CABLE

Silicone cable (3x0.5²)

Type summary

Nom.flow q _p [m ³ /h]	Size				
0.6	G3/4 x 110 mm	G1 x 130 mm			
1.5	G3/4 x 110 mm	G3/4 x 165 mm	G1 x 130 mm	G1 x 165 mm	G1 x 190 mm
3	G1 x 190 mm	DN20 x 190 mm			
3.5	G5/4 x 260 mm	DN25 x 260 mm			
6	G5/4 x 260 mm	DN25 x 260 mm			
10	G2 x 300 mm	DN40 x 300 mm			
15	DN50 x 270 mm				
25	DN65 x 300 mm				
40	DN80 x 300 mm				
60	DN100 x 360 mm				
150	DN150 x 500 mm				
400	DN250 x 600 mm		DN150 x 500 mm		
1000 ³⁾	DN250 x 600 mm				

³⁾ Not included in the Danish type approval.

Dimension sketches

ULTRAFLOW® TYPE 65-S/R, G3/4 AND G1

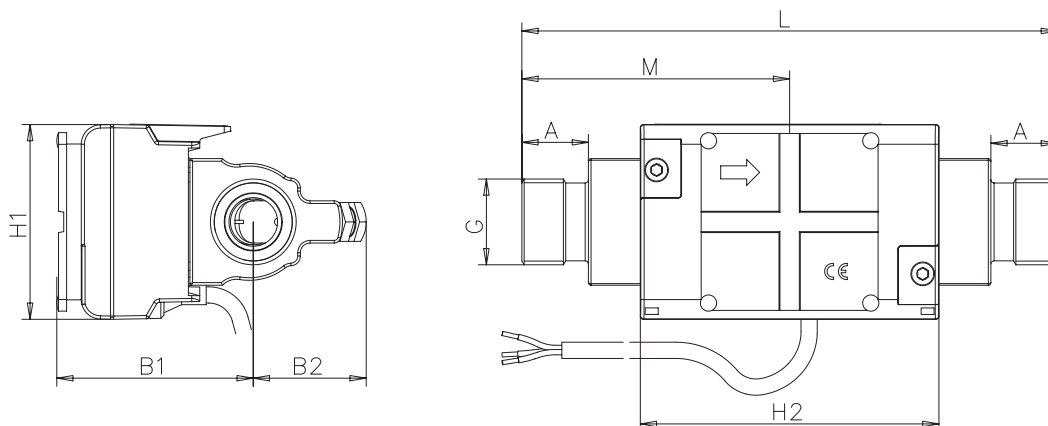

G	L	A	B1	B2	H1	H2	M	Approx. weight [kg]
3/4	110	10.5	61	35	60	92	L/2	0.8
1	130	20.5	61	35	60	92	L/2	0.9
3/4	165	20.5	61	35	60	92	L/2	1.2
1	165	20.5	61	35	60	92	L/2	1.2
1	190	20.5	61	35	60	92	L/2	1.4
1	190	20.5	60	36	60	92	L/2	1.3

ULTRAFLOW® TYPE 65-S/R, G5/4 AND G2

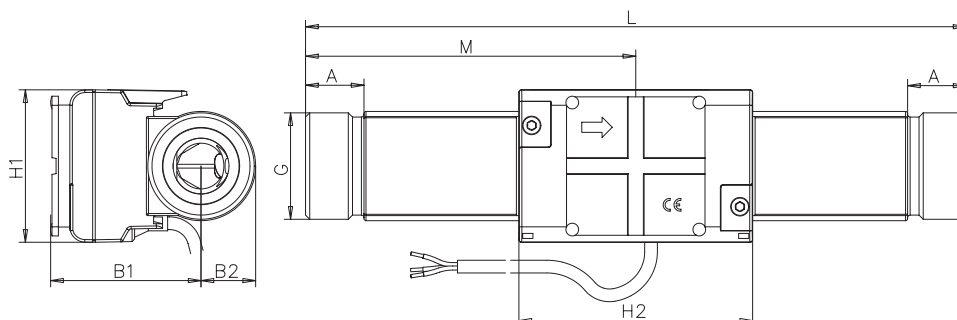

G	L	A	B1	B2	H1	H2	M	Approx. weight [kg]
5/4	260	23	60	22	60	92	L/2	2.3
2	300	30	68	31	60	92	L/2	4.5

Dimension sketches (continued)

ULTRAFLOW® TYPE 65-S/R, DN20 TO DN50

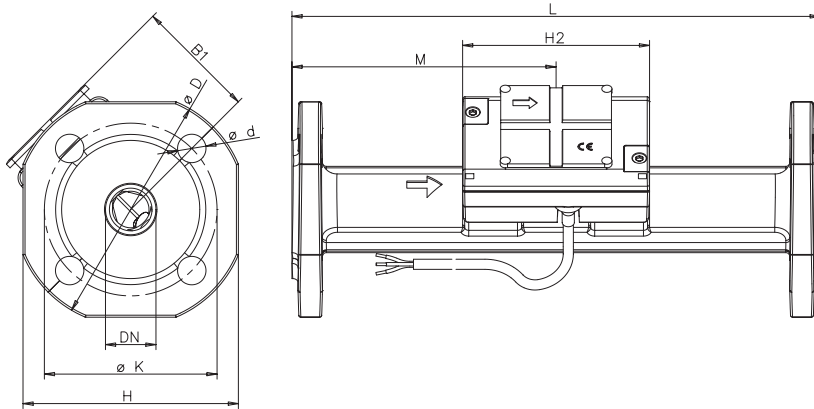

DN	L	B1	H	øD	H ₂	M	øK	ød	No.	App. wt [kg]
20	190	60	95	105	92	L/2	75	14	4	2.5
25	260	60	106	115	92	L/2	85	14	4	4
40	300	øD/2	136	150	92	L/2	110	18	4	6.9
50	270	øD/2	145	165	92	155	125	18	4	7.8

ULTRAFLOW® TYPE 65-S/R, DN65 AND DN80

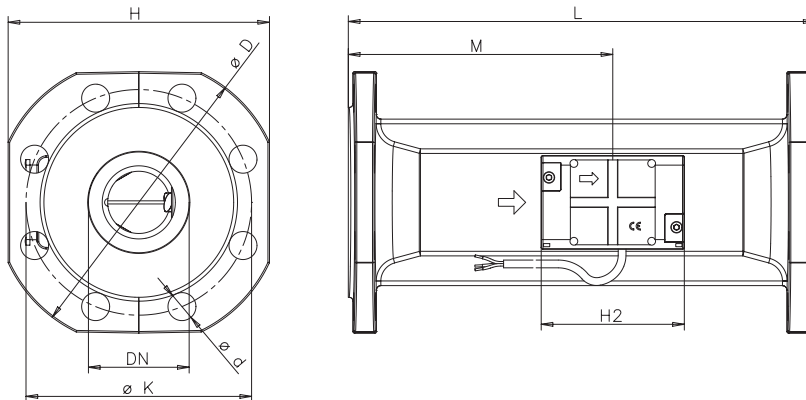

DN	L	B1	H	øD	H ₂	M	øK	ød	No.	App. wt [kg]
65	300	øH/2	168	185	92	170	145	18	8	10.9
80	300	øH/2	184	200	92	170	160	18	8	13.9

ULTRAFLOW® TYPE 65-S/R, DN100

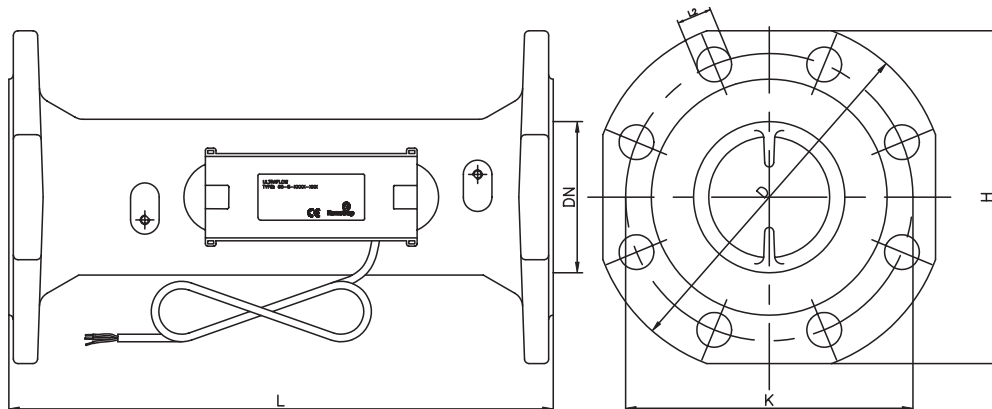

DN	L	H	øD	øK	L2	Bolt	No.	App. wt [kg]
100	360	220	235	190	23	M20	8	17

Dimension sketches (continued)

ULTRAFLOW® TYPE 65-S/R, DN150 AND DN250

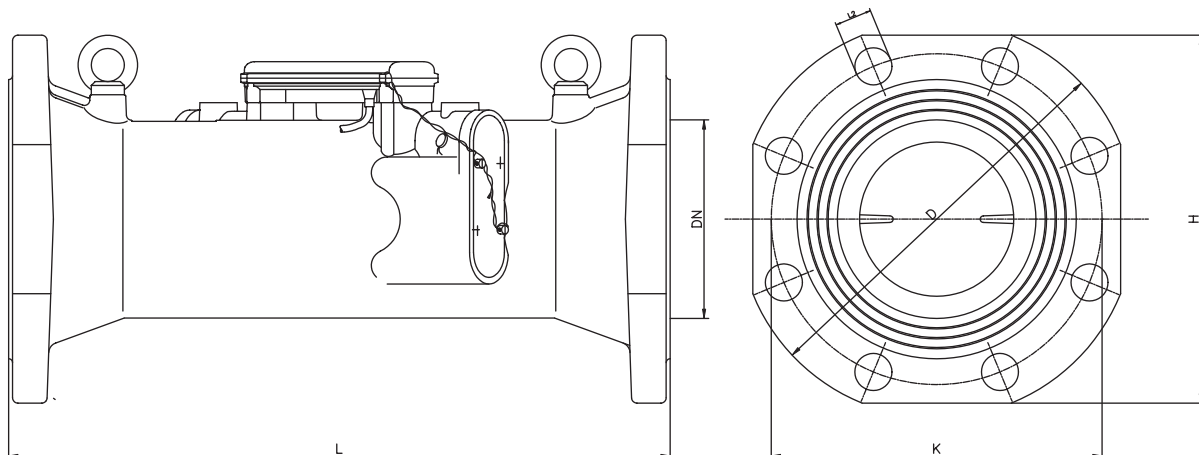

Nom. Diameter	L	H	øD	øK	L2	Bolt	No.	App. wt [kg]
DN150	500	278	300	250	28	M24	8	46
DN250	600	436	425	370	31	M27	12	126
DN250 (q_p 1000 m ³ /h)	600	436	425	370	31	M27	12	112

PULSE TRANSMITTER

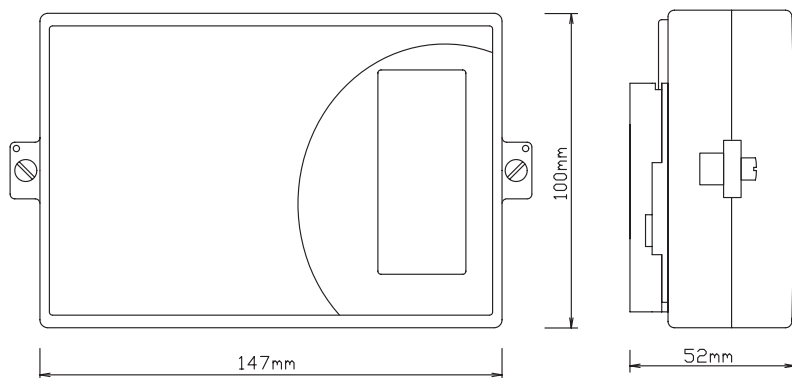

Pressure loss

Graph	q_p [m ³ /h]	Nom diameter [mm]	kv	Q@0.25 bar [m ³ /h]
A	0.6 & 1.5	DN15 & DN20	3	1.5
B	3 & 3.5 & 6	DN20 & DN25	15	7.5
C	10 & 15	DN40 & DN50	39	19
D	25 & 40	DN65 & DN80	89	45
E	60	DN100	155	78
F	150 & 400	DN150	948	474
G	400	DN250	3266	1633
H	1000	DN250	10000	5000

Pressure loss graphs

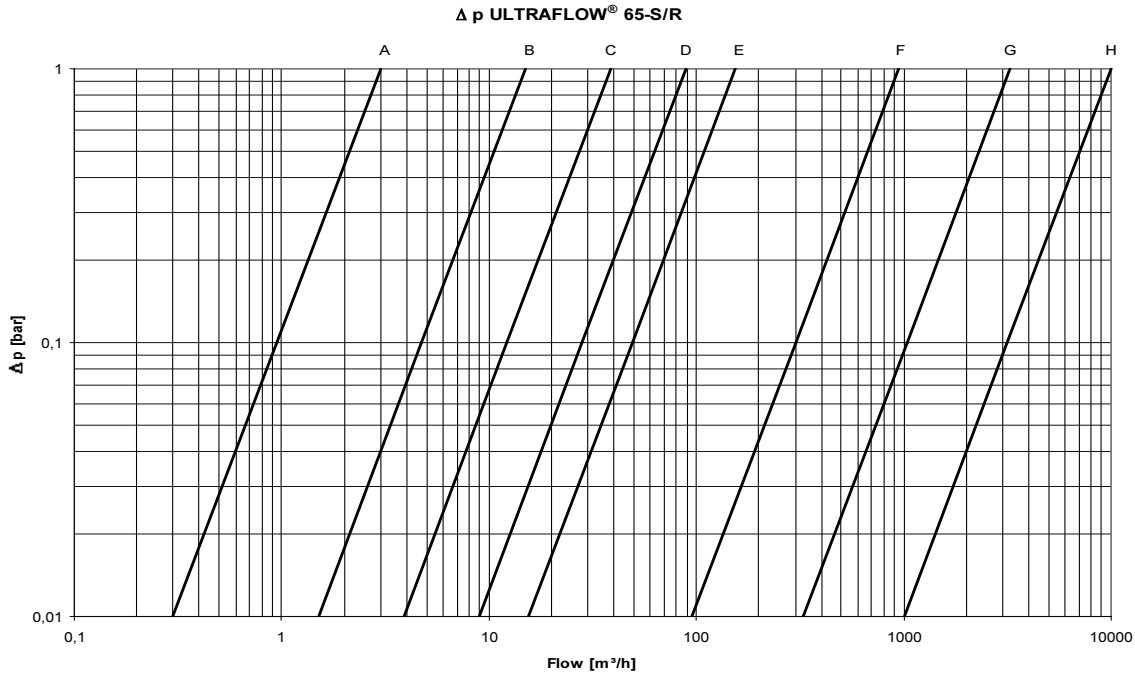

Installation

ULTRAFLOW® ≤DN100

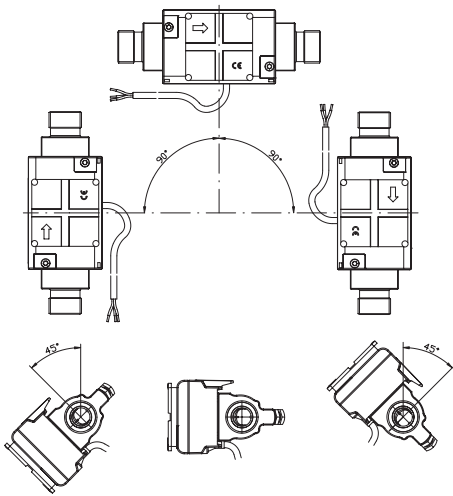

ULTRAFLOW® may be installed horizontally, vertically or at an angle.

IMPORTANT!

With ULTRAFLOW® ≤DN100 (60m³/h), the electronics/ plastic case must be placed to the side (with horizontal installation, ULTRAFLOW® may be turned up to ±45° in relation to the pipe axis).

ULTRAFLOW® ≥DN150

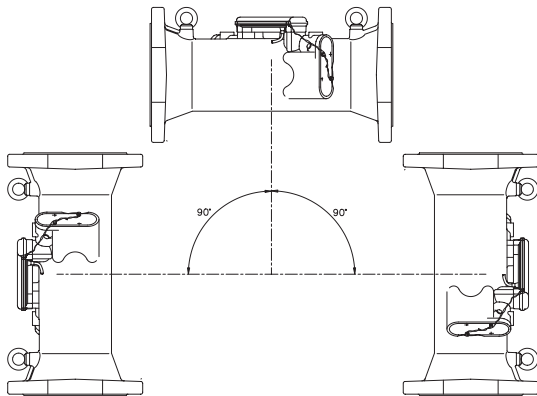

ULTRAFLOW® may be installed horizontally, vertically or at an angle.

IMPORTANT!

With ULTRAFLOW® ≥DN150 (150 m³/h), the electronics/ plastic case must be placed upwards (with horizontal installation, ULTRAFLOW® may be turned up to ±45° in relation to the pipe axis).

STRAIGHT INLET

ULTRAFLOW® ≤DN20 (G1) does not require a straight inlet.

The inlet for ULTRAFLOW® ≥DN25 (G5/4) must be 3...5 x DN.

Examples of installation

Gland meter with MULTICAL®/pulse transmitter fitted directly on ULTRAFLOW®.

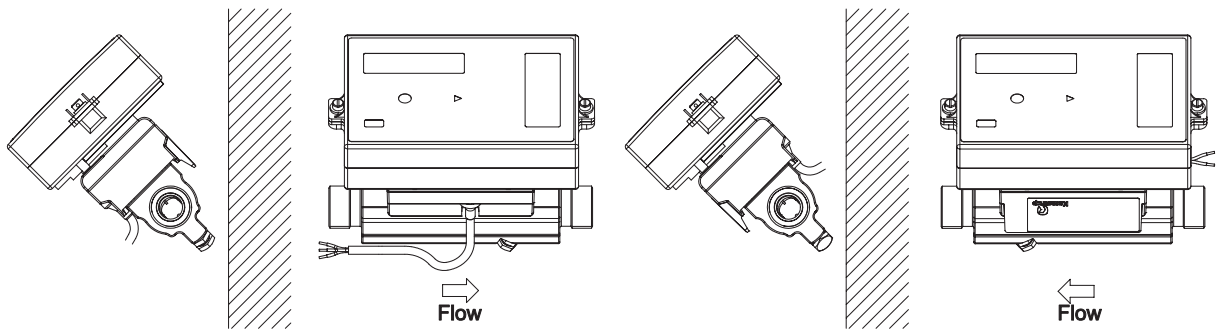

Glands and short direct sensor fitted in ULTRAFLOW® (G3/4 (R1/2) and G1 (R3/4) only)

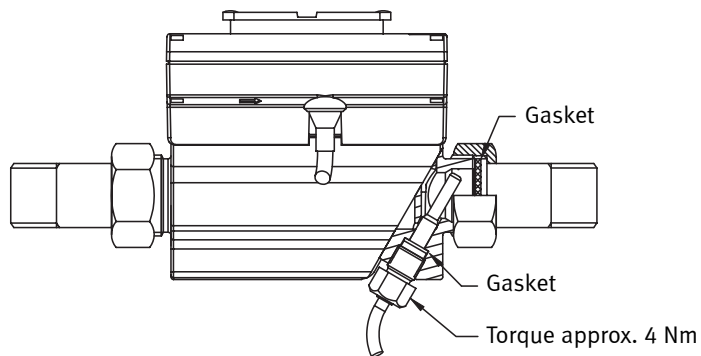

Flange meter with MULTICAL®/pulse transmitter fitted directly on ULTRAFLOW®.

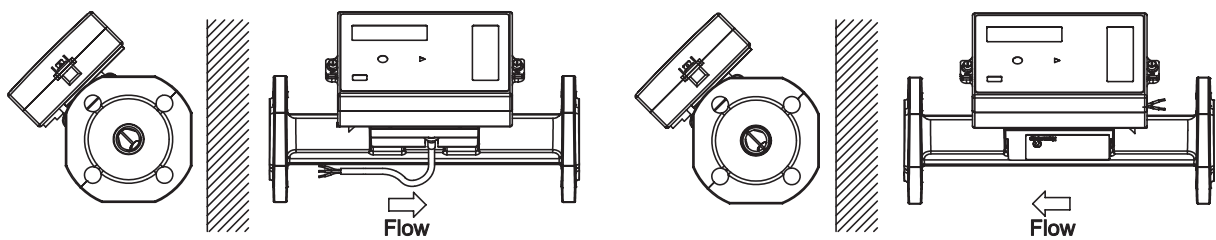

NB: For meters \geq DN100 MULTICAL® or the pulse transmitter can NOT be fitted directly on the flow part.

Electrical connection

CONNECTING MULTICAL®/MAXICAL & ULTRAFLOW®

ULTRAFLOW®	->	MULTICAL®, MAXICAL III
Blue (ground)	->	11
Red (supply)	->	9
Yellow (signal)	->	10

ULTRAFLOW®	->	Pulse transmitter	MULTICAL®
		In	Out
Blue (ground)	->	11	11A -> 11
Red (supply)	->	9	9A -> 9
Yellow (signal)	->	10	10A -> 10

CONNECTING VIA PULSE TRANSMITTER

3.65 V DC supply ⁷⁾	->	Pulse transmitter
Red (+)	->	60
Black (-)	->	61

ULTRAFLOW®	->	Pulse transmitter	MAXICAL
		In	Out
Blue (ground)	->	11	11A -> 11
Red (supply)	->	9	
Yellow (signal)	->	10	10A -> 10

⁷⁾ From battery or supply module.

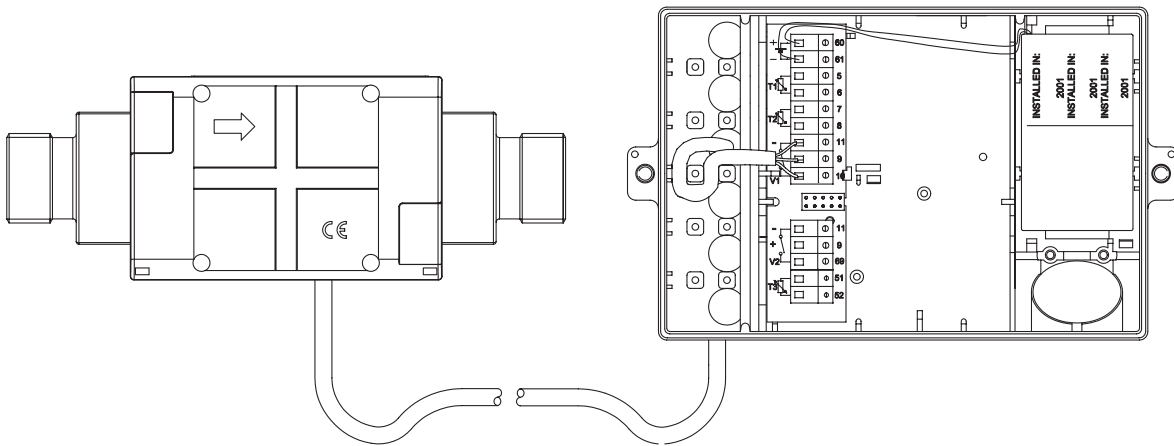

If long signal cables are used, please consider the installation carefully. There must be **at least 25 cm** between the signal cable and all other cables due to EMC.

Order specification

The list below shows type numbers for ULTRAFLOW® type 65-S with 2.5 m cable.

Type number ⁴⁾	q _p [m ³ /h]	q _i [m ³ /h]	q _s [m ³ /h]	Connection	Length [mm]	Meter factor [pulse/l]	CCC
65-S-CAAA-XXX	0.6	0.006	1.2	G3/4B (R ¹ / ₂)	110	300	116
65-S-CAAD-XXX	0.6	0.006	1.2	G1B (R3/4)	130	300	116
65-S-CDAA-XXX	1.5	0.015	3.0	G3/4B (R1/2)	110	100	119
65-S-CDAC-XXX	1.5	0.015	3.0	G3/4B(R ¹ / ₂)	165	100	119
65-S-CDAD-XXX	1.5	0.015	3.0	G1B (R3/4)	130	100	119
65-S-CDAE-XXX	1.5	0.015	3.0	G1B (R3/4)	165	100	119
65-S-CDAF-XXX	1.5	0.015	3.0	G1B (R3/4)	190	100	119
65-S-CFAF-XXX	3.0	0.03	6.0	G1B (R3/4)	190	50	136
65-S-CFBA-XXX	3.0	0.03	6.0	DN20	190	50	136
65-S-CGAG-XXX	3.5	0.035	7.0	G5/4 (R1)	260	50	151
65-S-CGBB-XXX	3.5	0.035	7.0	DN25	260	50	151
65-S-CHAG-XXX	6.0	0.06	12	G5/4B (R1)	260	25	137
65-S-CHBB-XXX	6.0	0.06	12	DN25	260	25	137
65-S-C1AJ-XXX	10	0.1	18	G2B (R1 1/2)	300	25	137
65-S-C1BD-XXX	10	0.1	18	DN40	300	25	137
65-S-CJAJ-XXX	10	0.1	20	G2B (R1 1/2)	300	15	178
65-S-CJBD-XXX	10	0.1	20	DN40	300	15	178
65-S-CKBE-XXX	15	0.15	30	DN50	270	10	120
65-S-C2BG-XXX	25	0.25	45	DN65	300	10	120
65-S-CLBG-XXX	25	0.25	50	DN65	300	6	179
65-S-CMBH-XXX	40	0.4	80	DN80	300	5	158
65-S-FABL-XXX	60	0.6	120	DN100	360	2.5	170
65-S-FCBN-XXX	150	1.5	300	DN150	500	1	147
65-S-FEBN-XXX	400	4	800	DN150	500	0.4	171
65-S-FEBR-XXX	400	4	800	DN250	600	0.4	171
65-S-F1BR-XXX	1000	10	1800	DN250	600	0.25	172

⁴⁾ XXX-code is determined by Kamstrup A/S in connection with assembly, approval etc.
Some sizes are not included in national approvals.

A standard ULTRAFLOW® 65-S is supplied with 2.5 m installation cable. However, ULTRAFLOW®, can also be supplied with 5 or 10 m cable.

When ordering ULTRAFLOW® with 5 or 10 m cable, please state type No. 65-R-????-XXX ⁴⁾ and the required cable length.

Pulse transmitter - type No. 66-99-603

The pulse transmitter is supplied with built in supply for ULTRAFLOW®. Battery, 24 VAC/DC or 230 VAC supply are available. Please state the required supply type when ordering.

Accessories

Glands including gaskets (PN10)		
Size	Type No.	(2 off)
DN15, (R $\frac{1}{2}$ x G3/4)	65-61-311	(65-61-321)
DN20, (R $\frac{3}{4}$ x G1)	65-61-312	(65-61-322)
DN25, (R1 x G5/4)	65-61-313	
DN40, (R1 $\frac{1}{2}$ x G2)	65-61-315	

Gaskets for glands	
Size	Type No.
G3/4	2210-061
G1	2210-062
G5/4	2210-063
G2	2210-065

Gaskets for flange meters	
Size	Type No.
DN20	2210-147
DN25	2210-133
DN40	2210-132
DN50	2210-099
DN65	2210-141
DN80	2210-140
DN100	2210-148
DN150	2210-149
DN250	2210-150

