

MOD-MBUS Modbus to M-Bus Converter Module

MOD-MBUS converter modules are used with any Modbus master to read M-bus meters. Converters are available to support up to 8 or up to 24 M-bus meters. The converters are configured with a configuration software that is used to map the M-bus readings to the Modbus addresses. The configuration software has M-bus meter templates for the most commonly used meters.

Both RS232 and RS485 models are available. RS-485 models allow multiple converters to be connected to Modbus master such as WebBiter web-browser interface.



Features

- Support for up to 8 or up to 24 M-bus Meters
- Easy configuration using template based configuration software
- RS485 Version for Multidrop applications
- RS232 Version for point to point applications
- DIN-rail mounted

Model Type	Model	Description
	MOD-MBUS-8/485	Modbus to M-Bus Converter, Up to 8 M-Bus Meters, RS485 Modbus Slave
	MOD-MBUS-8/232	Modbus to M-Bus Converter, Up to 8 M-Bus Meters, RS232 Modbus Slave
	MOD-MBUS-24/485	Modbus to M-Bus Converter, Up to 24 M-Bus Meters, RS485 Modbus Slave
	MOD-MBUS-24/232	Modbus to M-Bus Converter, Up to 24 M-Bus Meters, RS232 Modbus Slave
	MBUS-CONF	Configuration Software for the Converter
Technical Data	Power Supply	24Vdc <1VA, Range 18..30V
	Modbus	Modbus RTU Slave 9600 to 57600 bps, 8 Data Bits, Parity None, 1 Stop Bit
	Modbus Connection	RS232 or RS485 (depending on the model)
	M-Bus	MOD-MBUS-8: Up to 8 M-Bus Meters / Devices MOD-MBUS-24: Up to 24 M-Bus Meters / Devices
	M-Bus Comms	EN1434-3, 300 up to 38,400 bps, 8 Data Bits, Parity Even, 1 Stop Bit
	M-Bus Cable	Max.Cable Length: 350m Max Cable Capacitance: 180 nF
	Maximum Number of Modbus Parameters	MOD-MBUS-8: Up to 100 Data Points MOD-MBUS-24: Up to 198 Data Points
	Wiring Terminals	2.5 mm ² rigid 1.5 mm ² flexible
	Factory Settings	Modbus Address: 255 Modbus Baud Rate: 19200 M-Bus Baud rate: 300
	Mounting	DIN-rail
	Operating Temp	0..+60°C
	Operating Humidity	10..90% rH non-condensing
	Enclosure	IP20

Dimensions W23 x H85 x D70 mm

Connection Diagram

The below diagrams illustrate the wiring connections for the MODBUS/M-Bus conversion modules.

With RS232 Connection

With RS485 Connection

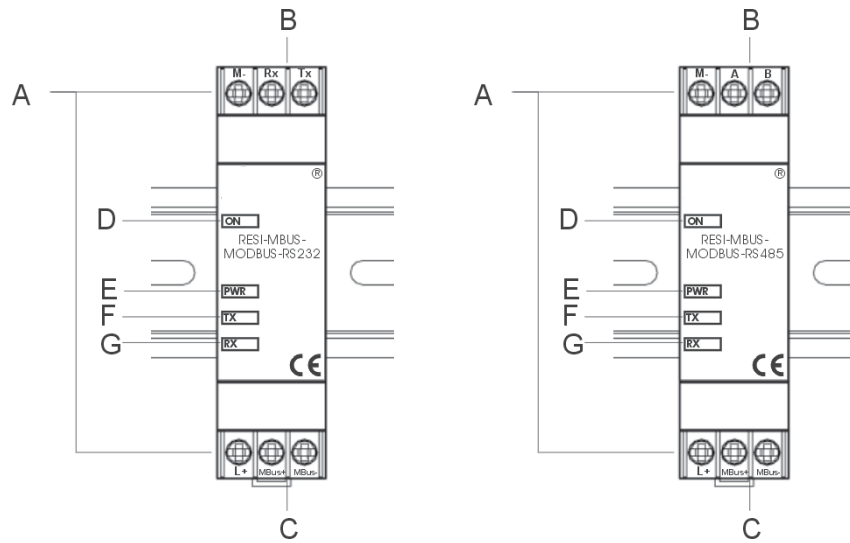

The modem operation is indicated by the LED. The table below lists the different states of the modem.

	RS232 Versions	RS485 Versions
A	Supply Voltage L+: 24V= (dc) M-: ground	Supply Voltage L+: 24V= (dc) M-: ground
B	RS232 Modbus Interface Rx: received data Tx: transmission data	RS485 Modbus Interface A: positive data line B: negative data line
C	M-Bus Interface M-Bus+ M-Bus-	M-Bus Interface M-Bus+ M-Bus-
D	Converter Status Indicator	Converter Status Indicator
E	Supply Indicator for M-Bus Interface	Supply Indicator for M-Bus Interface
F	Transmission Indicator of M-Bus Interface	Transmission Indicator of M-Bus Interface
G	Receiving Indicator of M-Bus Interface	Receiving Indicator of M-Bus Interface

Typical Network Diagram

MOD-M-BUS converters are typically used as the communication interface to M-bus meters. M-bus is the European EN1434-3 standard for communicating intelligent meters.

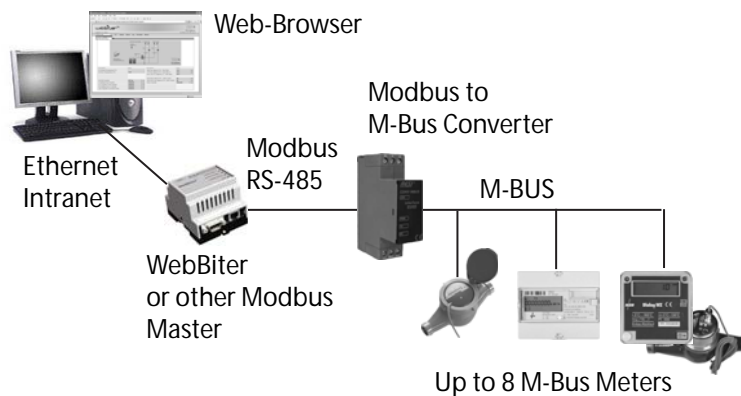

RS232 Modbus to M-Bus Connections

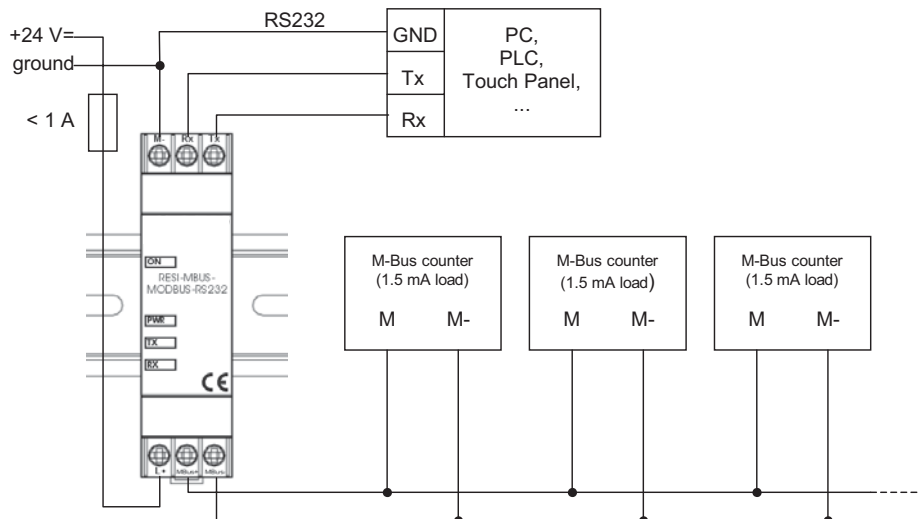

RS485 Modbus to M-Bus Connections

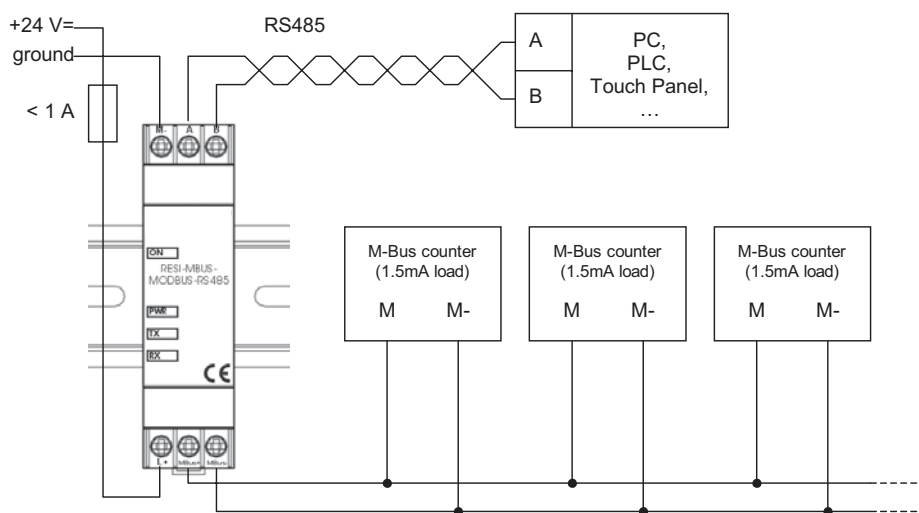

Functional Description

MBUS-MODBUS Converter automatically reads values out of Meter-Bus counters and allocates the values to Modbus Holding registers. Up to 100 values can be read via Modbus with the 8 M-Bus meter version and up to 198 parameters can be read with the 24 M-Bus meter version.

After switching on the supply voltage the converter checks for a valid configuration. If there is a valid configuration, the converter starts to initialise the Meter-Bus participants. Should there be no response after 3 consecutive attempts to initialise a participant, it is the turn of the next participant. The initialization of the not responding participant will restart every 5 scanning cycles.

The first scanning cycle starts after an interval of 5 seconds. The values of all initialised participants are read in and are written, depending on the configuration, in the respective Modbus registers.

As from now there will be the formerly configured pause between 2 scanning cycles. Should there be a participant not responding after 3 consecutive reading attempts, he will be initialised again in the next cycle. Should there be no response after 3 consecutive attempts to initialise a participant; initialization will restart every 5 scanning cycles. If the initialisation is successful, the participant will be read in the next cycle.

Most of the M-Bus Slaves read in new values on the next scan, i.e. on a new scan are read in no current values.

As there may be scanning recesses up to 18 hours configured, following algorithm anticipates that "old" values may be read in:

At scanning recesses more than 30 seconds, the converter calls, 30 seconds before the actual scan, all slaves to actualize their values.

For communication via Modbus are following Modbus features available:

- READ HOLDING REGISTER (function code: 3)
 - PRESET SINGLE REGISTER (function code: 6)
 - PRESET MULTIPLE REGISTERS (function code: 16)
-

Notes: In the view of a constant development of their products, the manufacturer reserves the right for changing technical data and features without prior notice.