

F 90

Heat Meter

Warmly recommended to cool-headed
economisers



- ✘ Available in three types for a multitude of job profiles.
 - PICO THERM 2e COMPACT – the economy heat meter without data outputs.
 - PICO THERM 2 COMPACT – the compact-size heat meter with data outputs.
 - PICO THERM 2 SPLIT – the split heat meter with data outputs.
- ✘ High-performance calculator – 37 monthly reporting days.
- ✘ Long-lived battery – lithium-energy.
- ✘ Reader-friendly LC display – for convenient monitoring.

F 90 Heat Meter

For state-of-the-art consumption recording with M-Bus on request

Computing virtuoso

The F 90 offers versatile capabilities for billing and monitoring. For small, medium-sized and large systems, depending on the version involved. It fully satisfies the stringent requirements of commercial heat metering.

The heart of the device is the calculator, which is controlled by a high-performance micro-processor functioning with indefatigable efficacy. At the touch of a button, the LC display indicates the heat consumption in MWh whenever needed.

System function

To put it simply, the system functions like this: a hot-water meter is installed in the system's return pipe – known in the trade as a volume measuring unit.

The rotor RPM is transmitted to the calculator, and evaluated together with the signals from the resistance temperature sensors. Each system incorporates two paired sensors, in the supply and return lines.

Depending on the metering job involved, the system can be delivered in different configurations: see Page 3. The components have been certified separately.

Convenient communication

Nor should this go unmentioned: if you have special requirements, we can offer an M-Bus interface to EN 1434-3.



Wide choice

Volume measuring units are available with all customary nominal flow rates, from Q_n 0.6 to Q_n 250, and can always be combined with the arithmetic-logic unit, thus opening up extensive application options.

As you can rightly expect, a steel hood protects the flow meter against manipulation.

Technical data can be found in our prospectus L 09.09 „Volume measuring units“.

Sensitivity

The Pt 100 resistance temperature sensors are certified in pairs. They must be installed with immersion shells in the supply and return pipes.

In the COMPACT and SPLIT Version 1 models, the return resistance temperature sensor is already located in the outlet socket of the volume measuring unit.

Typical

F 90

Precise

- ✘ High-performance calculator.
- ✘ Sensitive temperature sensors.
- ✘ Accurate volume measuring units.

Powerful

- ✘ Long-lived battery with energy guarantee for the entire calibration period.

Informative

- ✘ Easy-read LC display.
- ✘ Swivelling calculator in the COMPACT model.
- ✘ 37 monthly reporting days.
- ✘ Error messages.
- ✘ Economy heat meters without data outputs.
- ✘ Compact heat meters with multiple data outputs: M-Bus to EN 1434, opto-interface to EN 60870-5, 2 pulse outputs for heat quantity and volume.

In addition

- Available on request:
- ✘ COMPACT with AGFW sensor – directly immersed in the medium.

Approvals

Calculator

- F 90.

22.15
98.01

Temperature sensors

- WT.

22.30
82.07
- TSF.

22.30
96.06
- AGFW.

22.30
84.06

Volume measuring units

- Single-jet meter.

22.16
82.01
- Multi-jet meter.

22.16
80.07
- Woltmann meter WP.

22.16
87.02
- Woltmann meter WS.

22.16
86.01

System components

PICOTHERM 2e/2 COMPACT

For standard operation in the lower flow range. Thanks to modest dimensions, it's the ideal heat meter for domestic users. With interfaces for trouble-free reading from outside.

The economy heat meter is supplied without data outputs.

All components are already prewired – this simplifies installation considerably.

PICOTHERM 2e/2 COMPACT

For the lower flow range of

✘ Q_n 0.6 to Q_n 2.5, the heat meter system comprises three inter-connected components:

1. Calculator directly mounted on the volume measuring unit.
2. Supply flow temperature sensor.
3. Single-jet meter as volume measuring unit with return flow temperature sensor in the meter body outlet nozzle.

PICOTHERM 2 SPLIT version 1

For the lower flow range of

✘ Q_n 0.6 to Q_n 2.5, the heat meter system may also be supplied as three separate components:

1. Calculator to be wall-mounted.
2. Supply flow temperature sensor.
3. Single-jet meter as volume measuring unit with return flow temperature sensor in the meter body outlet nozzle.

PICOTHERM 2 SPLIT version 2

For the wide flow range of

✘ Q_n 1.0 to Q_n 250, the heat meter system comprises three separate components:

1. Calculator to be wall-mounted.
2. Supply and return flow temperature sensors as matched pair.
3. Single-jet meter, multi-jet meter or Woltmann meter as volume measuring unit.

Heat meters

Heat meters are generally designed on the basis of the constant cubic meter capacity required. If only the heat output (boiler output or connected load) and the temperature difference are known, the nominal flow may be calculated by the following formula.

$$Q_n = X \cdot \frac{P}{k \cdot \Delta t}$$

Where:

- X = 0.8
reduction factor to DIN 4701
P heat output in kW
k heat coefficient

$$= 1\,146 \frac{\text{kWh}}{\text{m}^3 \cdot \text{K}}$$

Δt temperature difference between supply and return flow in K.

Heat meter Nominal flow Q_n , m ³ /h	Heat output P for Δt 10 K		Heat output P for Δt 20 K		Heat output P for Δt 30 K	
	kW	...	kW	...	kW	...
0.6	0	9	0	18	0	27
1	10	14	19	28	28	42
1.5	15	21	29	42	43	63
2.5	22	35	43	70	64	105
3.5	36	50	71	100	106	150
6	51	86	101	172	151	264
10	87	143	173	286	265	429
15	144	214	288	430	430	645
40	215	570	430	1 040	646	1 710
60	580	860	1 050	1 720	1 710	2 580
150	870	2 140	1 740	4 300	2 600	6 420
250	2 150	2 900	4 300	5 800	6 430	8 700

The reduction factor makes allowance for the fact that, with the boiler output, a safety factor is included and also that the equipment in service runs for the most part below maximum output. When connected to district heating, the reduction factor may be omitted.

The heat coefficient used in the arithmetic example has been assumed as an average value sufficiently accurate for calculating the nominal flow Q_n .

Heat Meter

Compact heat meter				PICO THERM 2e / 2 COMPACT		
Meter size / nominal flow rate	Q_n	m^3/h		0.6	1.5	2.5
Nominal size	DN	inches		1/2	1/2	3/4
	DN	mm		15	15	20
Pulse rate		litres/pulse		10/1	10/1	10/1
D ₁	Meter connection thread	ISO 228/1	inches	G 3/4 B	G 3/4 B	G 1 B
D ₂	Connection pipe thread	ISO 7/1	inches	R 1/2	R 1/2	R 3/4
L ₁	Meter length		mm	110	110	130
L ₂	Connector length		mm	40	40	50
H ₁	Centerline height		mm	18	18	21
H ₂	Overall height		mm	101	101	101
K	Length	Temperature sensor cable	m	1.5	1.5	1.5
Weight			kg	0.8	0.8	1
Volume measuring unit				ETH-DA-KGm		
Installation	horizontal / riser					
Maximum flow rate	$Q_{max} = Q_n$	m^3/h		0.6	1.5	2.5
Transitional flow rate	Q_t	l/h		60	150	250
Minimum flow rate	Q_{min}	l/h		24	60	100
Continuous load		m^3/h		0.6	1.5	2.5
Temperature range	TB	°C		0 ... 90	0 ... 90	0 ... 90
Pressure rating		PN		16	16	16
Flow capacity	at 1 bar pressure loss	m^3/h		> 1.2	> 3	> 5

In accordance with PTB, as from 1 April 2001 mechanical volume measuring units may be designated only with Class A.

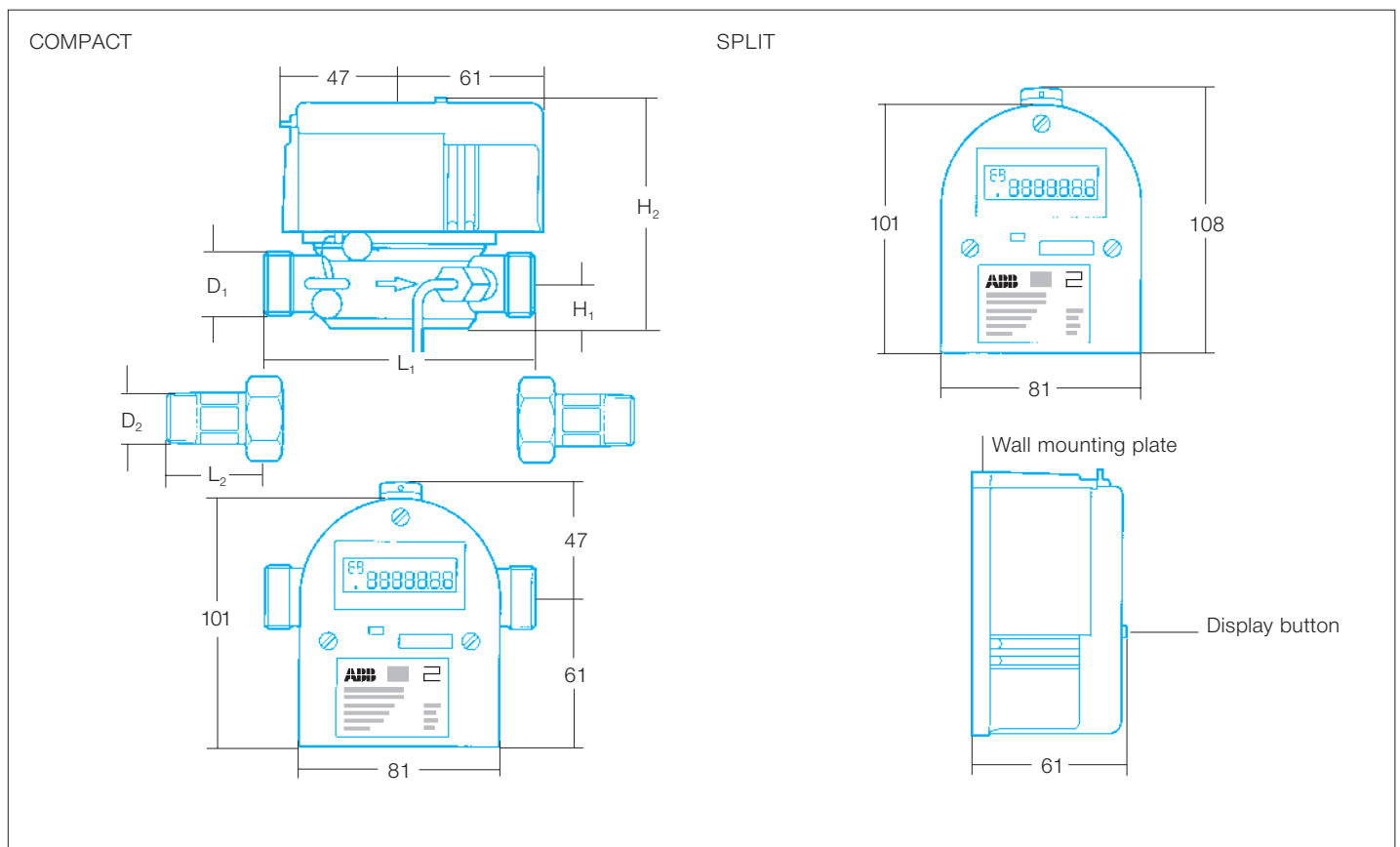

Calculators

Calculators		PICOTHERM 2e/2 COMPACT	PICOTHERM 2 SPLIT
Temperature range	TB °C	0 ... 130	0 ... 130
Temperature difference range	K	3 ... 120	3 ... 120
— Accuracy	Overfulfills the PTB guideline	✗	✗
Heat coefficient	Sliding	✗	✗
LC display	Digits	7	7
Digit height	mm	6	6
Operating informations	Displays	12	12
Error messages	Displays	✗	✗
Reporting days	Months	37	37
Display capacity			
— Q _n 0,6 ... 10	MWh	99999.99	99999.99
— Q _n 15 ... 100	MWh	999999.9	999999.9
— Q _n 150 ... 250	MWh	9999999	9999999
Pulse sequences			
— Q _n 0,6 ... 10	litres/pulse	10/1	10/1
— Q _n 15 ... 100	litres/pulse	—	100/1
— Q _n 150 ... 250	litres/pulse	—	250/1
Option	litres/pulse	—	0.05/1 ... 3 000/1
M-Bus data output	M-Bus	—	✗
— to EN 1434 optical interface	M-Bus	—	✗
— to EN 60870-5			
Pulse output			
— Heat consumption	Open collector	—	250 ms
— Volume	Open collector	—	250 ms
Power supply	Lithium battery	✗	✗
Capacity	V / Ah	3 / 1,8	3 / 1,8
Operating lifetime	Years	6	6
Ambient temperature	°C	0 ... 55	0 ... 55
Housing	Plastic	✗	✗
Degree of protection	DIN 40 050	IP 54	IP 54
Temperature sensor		Pt 100	Pt 100
Option		—	Pt 500

Sequence number	Operating information
10	Heat consumption MWh
11	Volume m ³
(12) 88	Display test: all display segments appear
15	Error code
20	Thermal output kW
21	Flow rate m ³ /h
22	High temperature °C
23	Low temperature °C
24	Temperature difference Δt °C
40	Reporting days (max. 37)* Date
41	Reporting days (max. 37)* Heat consumption
42 ... 47	Internal test Maintenance
51	Current date

LC display

The sequence number in the top left-hand corner indicates the value being shown on the display.

The left-hand digit designates the sequence, the right-hand digit the value inside a sequence.

Pressing the display button briefly will switch the display to the next value inside the sequence.

To change over to another sequence, press the display button until the left-hand digit advances. Release the button as soon as the display shows the sequence you want.

If the display button is not pressed for a lengthy period, sequence number 10 will appear, „Heat consumption in MWh“.

* Every first day of the month

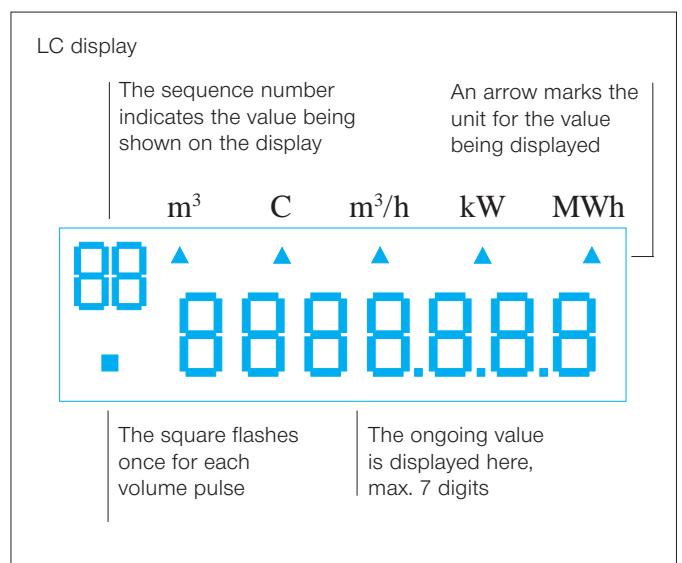
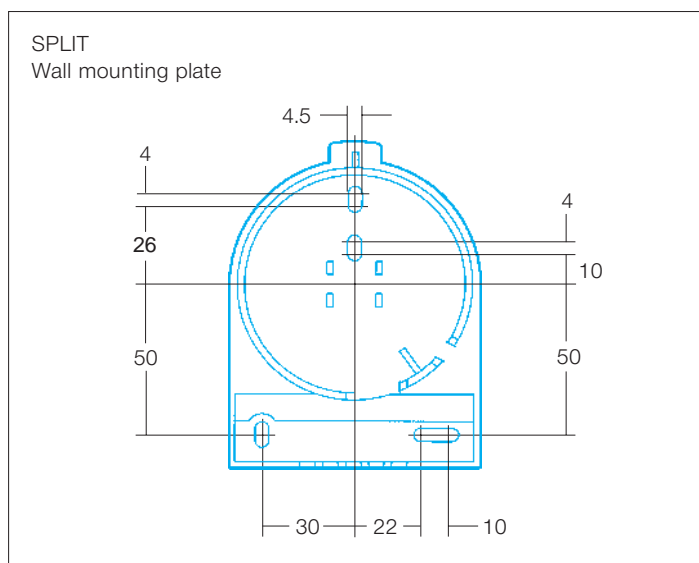

Temperature sensors

Temperature sensors	Standard	WT 34 / Pt 100	WT 85 / Pt 100	TSF 120 HU	AGFW / Pt 100
PICOTHERM 2e/2 COMPACT		✗	—	—	✗
PICOTHERM 2 SPLIT		✗	—	—	✗
Cable	Supply flow	1	—	—	1
Cable length	m	1.5	—	—	1.5
Sensor pocket	Type	TH 34	—	—	without pocket
	Brass	✗	—	—	—
PICOTHERM 2 SPLIT		✗	✗	✗	—
Cable	Scope of supply	2	2	—	—
Cable	Provided by user	—	—	✗	—
Cable length	m	3.0	3.0	—	—
Sensor pocket	Type	TH 34	TH 85	TPF 120	—
	Brass	✗	✗	—	—
	Stainless steel	—	—	✗	—
Measuring element	Platinum	✗	✗	✗	✗
Base value	Pt 100 DIN EN 60751	✗	✗	✗	✗
	Ohm	100 bei 0 °C	100 bei 0 °C	100 bei 0 °C	100 bei 0 °C
Temperature range	°C	0 ... 130	0 ... 130	20 ... 130	0 ... 140
Cable	D mm	4	4	—	4
	Silicone	✗	✗	—	✗
	2 x 0.25 mm ² Cu	✗	✗	—	✗
Sensor	D mm	5.2	5.2	6	3.3

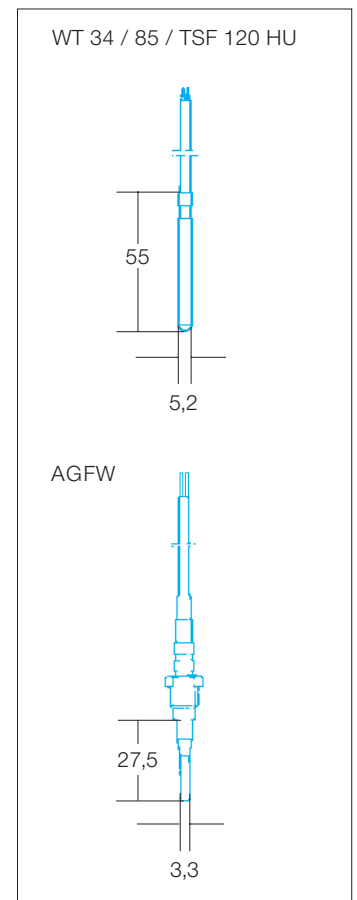
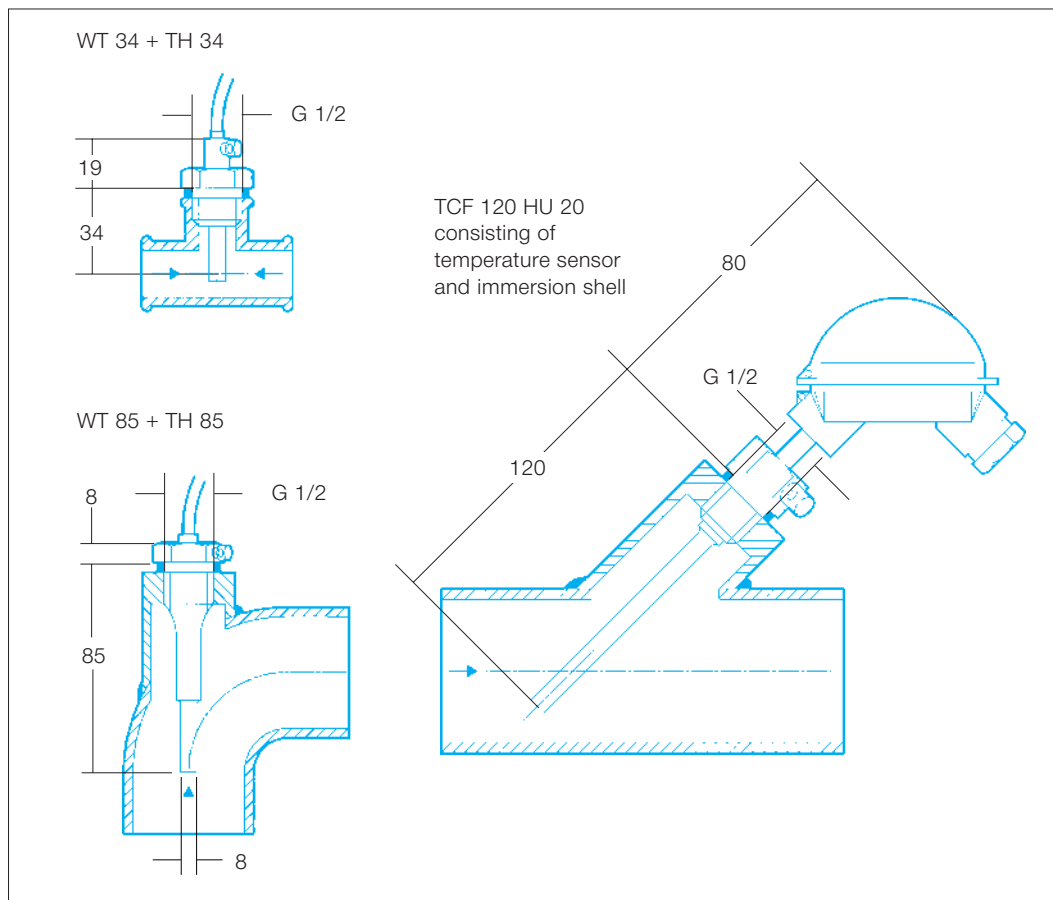

Ordering information

COMPACT

Complete – consisting of

Volume measuring unit single-jet meter ET,

with built-on calculator and 1 pair of temperature sensors, without pocket.
Installation kit – consisting of 1 meter replacement piece,
2 connectors complete, 1 T-piece, 1 immersion shell and seals.

Installation any position	PICOTHERM 2e/2 with WT 34 Order No.	Installation kit Type A R 1/2", 110 mm Order No.	Installation kit Type B R 3/4", 130 mm Order No.	PICOTHERM 2e/2 with AGFW Order No.
Q _n				
0.6	1199419/1118028	0204411	—	1146315
1.5	1199427/1118036	0204411	—	1146323
2.5	1199435/1118044	—	0204427	1146331

SPLIT Version 1

Complete – consisting of

Volume measuring unit single-jet meter ET,

calculator and 1 pair of temperature sensors, without pocket.
Installation kit – consisting of 1 meter replacement piece,
2 connectors complete, 1 T-piece, 1 immersion shell and seals.

Installation any position	PICOTHERM 2 with WT 34 Order No.	Installation kit Type A R 1/2", 110 mm Order No.	Installation kit Type B R 3/4", 130 mm Order No.
Q _n			
0.6	1145068	0204411	—
1.5	1145076	0204411	—
2.5	1144681	—	0204427

SPLIT Version 2

Complete – consisting of

Volume measuring unit multi-jet meter MT,

calculator, 1 pair of temperature sensors with immersion shells.

Installation horizontal	Thread WT 85/TH 85 Order No.	Thread TCF 120 HU 20 Order No.	Flange WT 85/TH 85 Order No.	Flange TCF 120 HU 20 Order No.
Q _n				
1	1145084	0658928	1145246	0658987
1.5	1145114	0658936	1145254	0658995
2.5	1145122	0658944	1145262	0659002
3.5	1145130	0658952	1145270	0659010
6	1145149	0658960	1145289	0659029
10	1145157	0658979	1145297	0659037
15	—	—	1145300	0659045

SPLIT Version 2

Complete – consisting of

Volume measuring unit single-jet meter ET / multi-jet meter MT,

calculator, 1 pair of temperature sensors with immersion shells.

Installation riser downpipe	Riser Thread WT 85/TH 85 Order No.	Thread TCF 120 HU 20 Order No.	Downpipe Thread WT 85/TH 85 Order No.	Thread TCF 120 HU 20 Order No.
Q _n				
1	—	—	—	—
ET 1.5	1171638	0659584	1171638	0659584
ET 2.5	1171646	0659592	1171646	0659592
MT 3.5	1145424	0659096	1145556	0659169
MT 6	1145432	0659118	1145564	0659177
MT 10	1145440	0659126	1145572	0659185
15	—	—	—	—

SPLIT Version 2

Complete – consisting of

Volume measuring unit Woltmann meter WP,

calculator, 1 pair of temperature sensors with immersion shells.

Installation any position	PN 16 WT 85/TH 85 Order No.	PN 16 TCF 120 HU 20 Order No.	PN 25/40 WT 85/TH 85 Order No.	PN 25/40 TCF 120 HU 20 Order No.
DN				
50	1145661	0659193	1145823	0659274
65	1145688	0659207	—	—
80	1145696	0659215	1145831	0659282
100	1145718	0659223	1145858	0659290
125	1145726	0659231	—	—
150	1145734	0659258	1145866	0659304
200	1145742	0659266	1145874/0632066	0659312

SPLIT Version 2

Complete – consisting of

Volume measuring unit Woltmann meter WS,

calculator, 1 pair of temperature sensors with immersion shells.

Installation horizontal	PN 16 WT 85/TH 85 Order No.	PN 16 TCF 120 HU 20 Order No.	PN 25/40 WT 85/TH 85 Order No.	PN 25/40 TCF 120 HU 20 Order No.
DN				
50	1145939	0659320	1146056	0659371
65	1145947	0659339	1146064	0659398
80	1145955	0659347	1146072	0659401
100	1145963	0659355	1146080	0659428
125	—	—	—	—
150	1145971	0659363	1146099	0659436
200	—	—	—	—

Calculator SPLIT

Display MWh	Pulse sequence	Order No.
	1 / 1	on request
	10 / 1	1146218
	100 / 1	1146226
	250 / 1	1146234

SPLIT Version 1

Volume measuring unit single-jet meter ET

With built-in immersion shell for return temperature sensor Installation any position	Q _n	Order No.
	0.6	0584935
	1.5	0585083
	2.5	0585277

Connectors

Natural brass, with seal	Inches	Pieces	Order No.
	1/2	1 pair	0607064
	3/4	1 pair	0607071
	1	1 pair	0511276
	1 1/2	1 pair	0607087

Extension and adapter pieces

Natural brass	Type	Pieces	Order No.
	1/2" - 110 x 3/4" - 110	1 piece*	0204434
	1/2" - 110 x 3/4" - 130	1 piece*	0506937
	1/2" - 110 x 3/4" - 190	1 pair	0508148
	1/2" - 110 x 1/2" - 165	1 piece	1109789
	3/4" - 130 x 3/4" - 190	1 piece	1109991
	3/4" - 130 x 1/2" - 165	1 pair	0517191

* 2 pieces required per meter

Temperature sensors

Immersion shells

Type	Length m	Order No. 1 pair	Type	Order No. 1 piece
WT 34 / Pt 100	1.5 / 3	0207839/0207846	TH 34	0207876
WT 85 / Pt 100	3	0207853	TH 85	0207883
TSF 120 HU with Anschlusskopf	—	0658871	TH 120	0658898
TCF 120 HU 20 1 pair of sensors with immersion shell, without cable				Installation kit 0659479

AGFW sensors

Type	Length m	Pieces	Order No.
AGFW 27.5 Pt 100	1.5	1 pair	1140155
Accessories	Inches		Order No.
Ball valve Brass nickel-pl. Brass nickel-pl.	G 1/2 G 3/4	1 piece 1 piece	1141119 1141127
Reduction union Brass natural	G 1/2 x M 10 x 1	1 piece	1141100
Adapter MK-01 For direct sensor installation	G 1/2	1 piece	0629758