

EnergyMetering

## WPH-N 90° C

*Woltman meter with parallel turbine shaft for water up to 90° C*



**ZENNER**  
*All that counts.*

## WPH-N 90° C

### Woltman meter with parallel turbine shaft for water up to 90° C



Woltman Parallel type meters are always used when high flow rates with a relative constant flow rate profile are to be measured. Through its robust construction they not only are capable of covering a large measuring range, but the measuring accuracy is also long-term stable.

The hydrodynamic optimized turbine is reliably operated already at small flow rates and “upwards” it has enough power reserves to reliably measure flow rate peaks. Especially strong bearings with low friction guarantee a long life of the meter.

Reed sensors, optical and inductive-NAMUR sensors can always be retrofitted without damaging the calibration seal. Then the meter can be integrated with data communication or automation and control systems in a simple and flexible way.

### Performance characteristics in overview

- Low starting flow, high overload security
- Wide measuring range
- Removable measuring insert
- Low head loss
- Hydraulic bearing relieve for long-term measuring stability
- Retrofittable with active and passive pulsers
- Metal protective cover serially, plastic optional
- Evacuated counter protected from condensation
- Dry dial counter with large number rollers simplifies the readability
- For water up to 90° C
- For horizontal, vertical and inclined installation positions

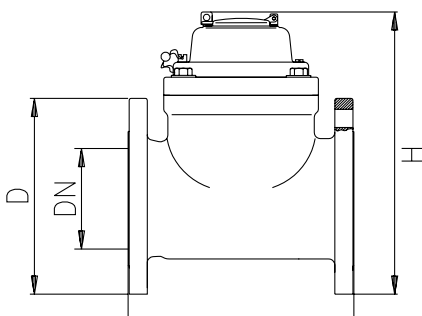

Dimensions WPH-N

Technical data WPH-N									
Nominal flow	Qn	m³/h	15	25	40	60	100	150	250
Nominal diameter	DN	mm	50	65	80	100	125	150	200
Overall length	L	mm	200	200	225	250	250	300	350
Metrological class			B	B	B	B	B	B	B
Maximum flow (short-term)	Qmax	m³/h	90	120	150	250	300	350	650
Maximum flow (constant)		m³/h	30	50	80	120	200	300	500
Transitional flow	Qt	m³/h	3	5	8	12	20	30	50
Minimum flow	Qmin	m³/h	0,6	1,0	1,6	2,4	4,0	6,0	10
Flow rate with 0.1 bar head loss		m³/h	30	50	70	100	150	200	650
Head loss at Qmax		bar	0,1	0,1	0,2	0,2	0,2	0,2	0,05
Display range	min	l	2	2	2	2	2	20	20
Maximum dial indication	max	m³	9.999.999						
Maximum temperature		°C	90	90	90	90	90	90	90
Operating pressure, max.	PN	bar	16	16	16	16	16	16	16
Height	H	mm	210	218	280	290	310	320	375
Flange diameter	D	mm	165	185	200	220	250	285	340

## Installation

WPH type Woltman meters can be installed horizontally or vertically, that is in horizontal or in perpendicular pipelines; the counter either is facing upwards or is tilted 90° to the side.

Woltman meters are by construction sensitive to the incident flow profile. Tee pieces or gate valves that are not completely opened within close proximity to the meter, effectively influence the measuring result.

### Exemplary the most important installation rules:

- Woltman meters must be operated in the correct flow direction.
- There must be a minimum of 3 x DN of straight pipe section for WPH type upstream of the meter.
- If a sufficient straight pipe section is not possible, then a honeycomb flow straightener should be installed.
- Ideally a straight pipe section of at least 2 x DN is present downstream of the meter.
- To avoid air pockets in the meter, it should not be installed on the highest point of the piping.
- Gate valves or other shut-off valves in front of the meter should be completely opened during operation.
- The overhead installation is not permitted.

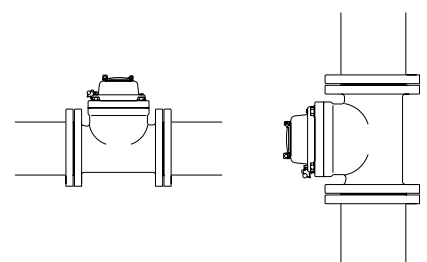
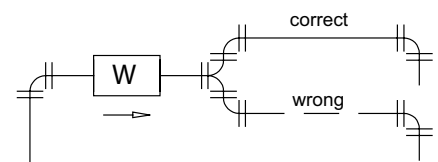
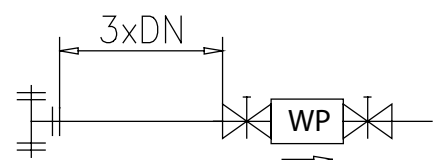

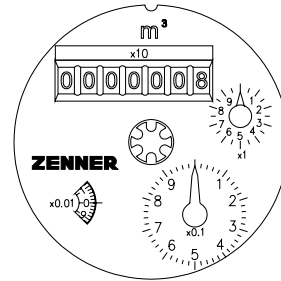
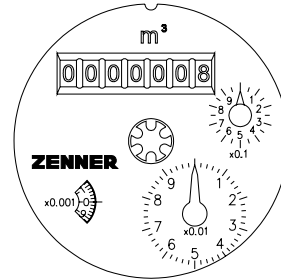

Dial from DN 150 to DN 200

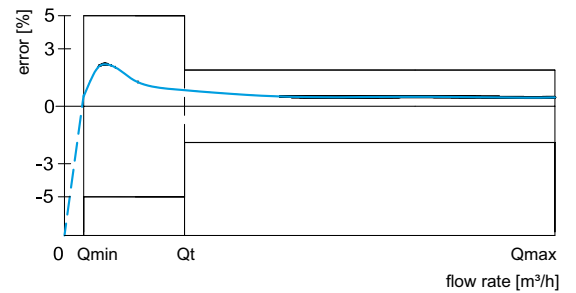
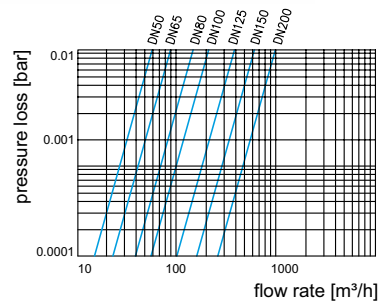

Technical data Pulser		
Pulser	Pulse value	Pulse value
	DN 50 – 125	DN 150 – 200
Reed sensor	0,1 and 1 m³	1 and 10 m³
Optical sensor	0,001 m³	0,01 m³
Inductive-NAMUR sensor	0,001 m³	0,01 m³

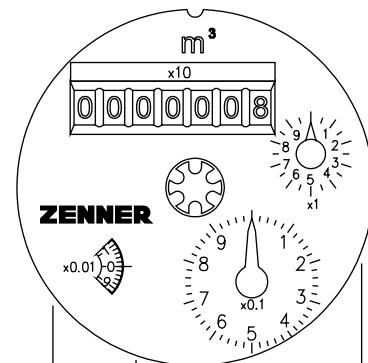

Reed sensor 1  
Inductive-NAMUR/Optical sensor  
Reed sensor 2