

620/620M

Volumetric Meter
Dry Dial



Main characteristics

DN 15 to 40, PN 16

Unrivalled accuracy and measuring range

Small pressure drop

High resistance to impurities

Quiet operation

Available with EEC and MID approvals (DN 15 & 20)

Benefit

The 620 is a high precision meter.

Due to its unique piston measuring chamber even drops of water are counted.

A clear view is either provided through a register with an integrated wiper or a sealed metal/glass register that does not fog. For a faster and more comfortable readout the 620 is prepared for AMR.

Due to our broad product range of system solutions you can adapt the 620 to all your AMR needs.

Not least by its tamper proof design and its long life span you will be glad you used the 620.

Available options

HRI electronic sensor (Pulse Unit, Data Unit, Radio Sensus((S))cout)

Connectors

Non-return valve

Metal/glass register

Accuracy

The development of a new material with a density close to that of water and an enhanced quality of surface finish results in a piston that glides easily in the measuring chamber at very low flows. The smallest leakage downstream of the meter can therefore be registered.

The measuring range of the 620 meter is much wider than class C requirements. With the approval according to the new MID regulation a Q3/Q1 ratio up to 400 can be obtained that combines the precision at both small and high flowrates.

Reliability

The exclusive composite material of the piston of the 620 meter combine lightness and excellent surface conditions. The piston can move in the measuring chamber without friction and also with very low wear.

Foreign matter present in water can be filtered first by the tubular strainer, then by the seat strainer. The smallest particles can go through the meter without damage; the elastic pivot enables the particles to pass between the piston and the measuring box. In this case, the surface hardness of the piston and the measuring box avoids scratches.

All the gears are situated in the dry part of the meter (totalizer), which removes any risk of blockage due to suspended matter in the water.

The 620 water meter keeps its metrological accuracy for many years of operation, even in very difficult working conditions.

Register

The display of 8 drums (5 for m³, 3 for litres) and 1 pointer ensures perfect readability. The lowest resolution is 0.05 litres. The dial has a central disc whose rotation indicates the passage of water. This indicator can be used to reveal a downstream leak.

The plastic register is equipped with a wiper for optimum legibility under all conditions. The 620 water meter can operate in any position and its dry dial can rotate up to 350°. The dial can therefore be easily read under all conditions of use.

When meters are installed in a very humid environment (external pit for example) the 620 meter(*) can be supplied with a metal/glass register giving the guarantee of index readability.

Typical Accuracy Curve

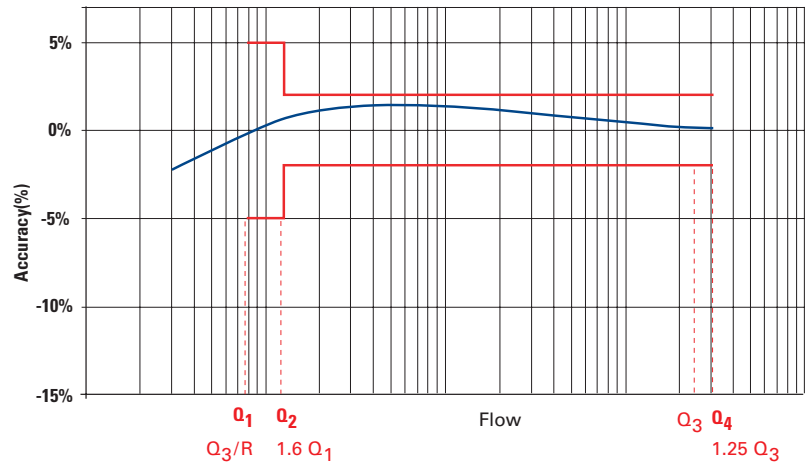

Typical Pressure Drop Curve

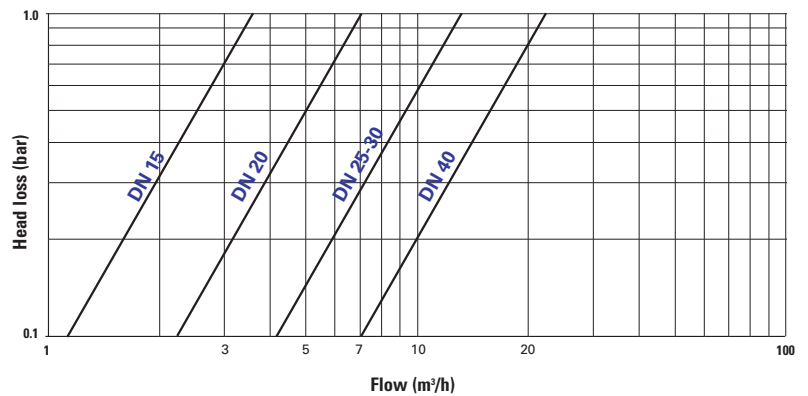

Cross Section

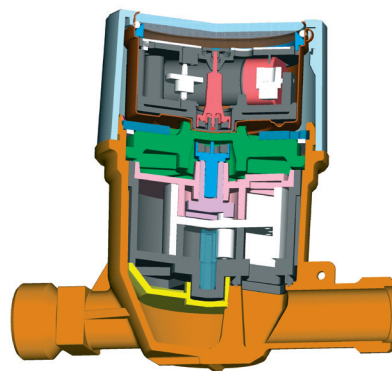

In-line version

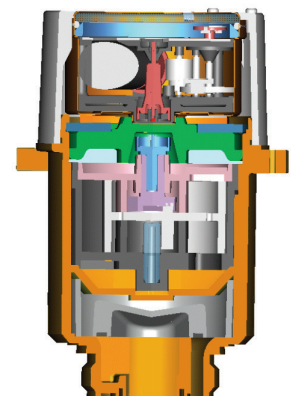

Co-axial version

Tampering Protection

The 620 meter is designed with tamper protection to avoid any misuse of the meter.

The plastic register is equipped with a tamper indicator (blue pin) whose breakage provides obvious evidence of any tampering attempt with a screw clamp for example. When using a metal/glass register, a clear glass break will then occur.

The meter is always equipped as standard with magnetic protection to protect the magnetic transmission against magnetic fields.

Any attempt to open the meter bonnet will cause this plastic part to break.

Approvals

EC pattern approval:
in conformity with

- 75/33/EEC
- 71/316/EEC

DN 15 & 20	D.96/6.123.05
DN 25 & 30	B.83/32.38
DN 40	B.77/32.04

EC type-examination certificate:
in conformity with

- 2004/22/EC (MID)
- EN 14154:2007
- OIML R49:2006

Q ₃ 2,5	DE-07-MI001-PTB002
Q ₃ 4	DE-07-MI001-PTB004

Certificate of compliance for potable drinking water

KTW/DVGW (D)	Hydrocheck (B)
ACS (F)	KIWA (NL)
WRAS (UK)	

Dimensional Diagram

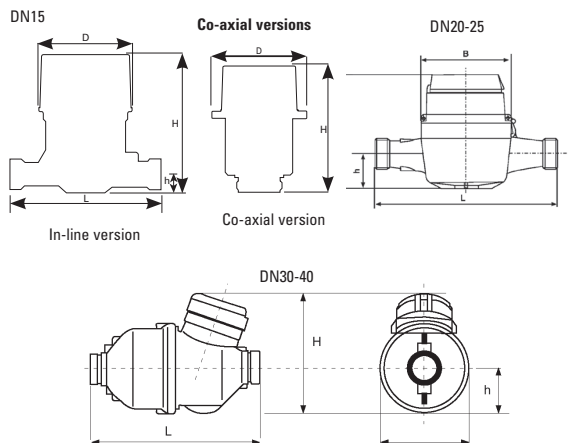

Performance Data

Metrological Characteristics - EEC Directive 75/33

Nominal Diameter DN	mm	In-line					Co-axial	
		15	20	25	30	40	Manifold	
Nominal flowrate Q _n	m ³ /h	1.5	2.5	3.5 ⁽¹⁾	6	10	1.5	
Maximum flowrate Q _{max}	m ³ /h	3	5	7	12	20	3	
Minimum flowrate (tolerance ±5%) Q _{min}	l/h	15	25	35	60	100	15	
Transitional flowrate (tolerance ±2%) Q _t	l/h	22.5	37.5	52.5	90	150	22.5	

⁽¹⁾ Also available with Q_n 6

Metrological Characteristics - Directive 2004/22/EC (MID) & EN 14154

Nominal Size DN	mm	In-line			Co-axial	
		15	20	Manifold		
Permanent flowrate Q ₃	m ³ /h	2.5	4	2.5		
Ratio "R" Q ₃ /Q ₁	R	40 / 80 / 160 / 315 / 400				
Maximum flowrate ⁽¹⁾ Q ₄	m ³ /h	3.125	5.0	3.125		
Minimum flowrate (tolerance ±5%) Q ₁	l/h	6.3	10.0	6.3		
Transitional flowrate ⁽¹⁾ Q ₂	l/h	10.0	16.0	10.0		

⁽¹⁾ Values for R = 400

Operational Characteristics (manufacturer's data)

Nominal size DN	mm	In-line					Co-axial	
		15	20	25	30	40	Manifold	
Starting flowrate ⁽¹⁾	l/h	<1	<2	7	7	8	<1	
Minimum flowrate (±5%) ⁽¹⁾		3	6	11	11	20	3	
Transitional flowrate (±2%) ⁽¹⁾		5	12	16	16	30	5	
Maximum registration	m ³	10 ⁵						
Lowest resolution	l	0.05						
Pressure loss at Q _{max}	bar	0.7	0.5	0.28	0.83	0.8	0.7	
Maximum Working Pressure PN	bar	16						

⁽¹⁾ typical performance characteristics

Dimensions and Weights

Dimensional Characteristics

Nominal size DN	mm	In-line					Co-axial	
		15	20	25	30	40	Manifold	
Length L	mm	170 ⁽¹⁾	190 ⁽³⁾	260 ⁽⁴⁾	260	300	n/a	n/a
Width D	mm	79.7	93.5	135	135	150	100	93
Total height H	mm	132.7	123	186	186	193	135.6	160
Height to pipe axis h	mm	15.5	37.5	68	68	75	n/a	n/a
Tail piece Diameter	inch	G ³ / ₄ "B ⁽²⁾	G1" B	G1 ¹ / ₄ " B	G1 ¹ / ₂ " B	G2" B	G1 ¹ / ₂ " B	G1 ¹ / ₂ " B
thread Pitch	mm	26.44	33.25	41.91	47.80	59.61	47.80	47.80
Weight	kg	1.81	2.31	2.31	2.31	2.31	2.31	2.31
	kg	1.0	1.6	3.7	3.8	5.0	1.0	1.35

⁽¹⁾ also available in length 110, 114, 115, 130, 134 and 165 mm

⁽²⁾ also available in length 165mm with 1" threads

⁽³⁾ also available in length 165mm

⁽⁴⁾ also available in length 198mm (with Q₃ 4)

Typical Marking



Marking can vary according to different market or metrological specifications.

AMR fitting

The dial of the 620 meter is equipped as standard with a pointer able to activate the HRI sensor. The HRI reproduces the mechanical register index exactly, by detecting the direction of rotation of the pointer. It provides a reliable pulse- and data interface for remote and mobile readout. The HRI can be fitted in the field on already installed Sentinel water meters or ordered factory fitted to the meter.

For more information refer to the leaflets

LS 8100 and LS 3300

The HRI is available as three versions:

1. HRI Pulse Unit (A-version)

The litre pointer activates the HRI allowing a basic resolution of one litre per pulse. The output pulse value can be factory set using the divisor D (e.g. D = 100 means 1 pulse per 100 litres).

The possible pulse output D values are:

1 / 10 / 100 / 1000 / 2.5 / 25 / 250

2. HRI Data Unit (B-version)

The HRI Data Unit is a data interface which supplies the meter reading as well as the serial or customer number. This version additionally provides a pulse output as described above.

The HRI Data Unit can be connected to a M-Bus network for remote read or a MiniPad for mobile inductive read (MiniBus), both in accordance with the IEC 870 protocol.

3. Sensus((S))cout-S Radio Unit

Integrated Sensus((S))cout radio with the usage of long term proven and reliable HRI sensing technology. Radio read is made via the handheld Psion WA pro and Dokom mobile (WinCE) software

Installation and Maintenance Instructions

For complete installation instructions, please refer to MD1001INT manual. The 620 meter must be installed in a low point of the pipeline, with the arrow cast on the body showing direction of the water flow. Before fitting the water meter, all pipework must be flushed out to remove all impurities.

An upstream stop valve is recommended to allow installation and removal of the water meter.

During tightening, the meter must be maintained in position with a standard tool using the flat on the meter body.

When turning on the water supply, the upstream valve must be opened slowly so that the water fills the meter as smoothly as possible.

No special maintenance is required.



Certified according to ISO 9001
Quality Management System OQS Reg.no. 3496/0

UK & Ireland Enquiries

Sensus Metering Systems 11 The Quadrangle, Abbey Park, Romsey, Hampshire SO51 9DL UK
T: +44 (0) 1794 526100 F: +44 (0) 1794 526101 Email: info.gb@sensus.com www.sensus.com

International Enquiries

Sensus GmbH Ludwigshafen Industriestrasse 16, 67063 Ludwigshafen Germany
T: +49 (0) 621-6904-0 F: +49 (0) 621-6904-1409 Email: info.int@sensus.com www.sensus.com

09001 Subject to changes without prior notice.