

## Solenvis SL71 Dynameters

### Ultrasonic Level Meter -

### Series DynaProbe Level Meter

This uses sound waves to measure liquid or solid level. Fast, accurate measurements are possible in the field or anywhere without the use of down-hole water level meters. The Ultrasonic Level Meters are lightweight, compact, versatile, and easy to operate. As long as the obstructions take up no more than half of the bore area the meter will not suffer any loss of accuracy.

#### Features:

- ◆Integrated design, installed conveniently
- ◆two wire transmitter standard, guarantee that the powerful sound wave is launched , that measurement is steady and reliable
- ◆Protected in the excessive voltage and current , protected in the thunder and lightning
- ◆The big show window of LCD is easy to debug and observe
- ◆Intellectual signal treatment technology, guarantee that the instrument meets various kinds of operating occasion
- ◆All plastic outer cover ( IP67 ), airproof and alkali-resisting, meet the abominable environment
- ◆Flexible support or flange are used to install.



Complete type



Combined type

#### MAKE UP & STRUCTURE

**1. Complete type: Range: 4m 6m 8m 10m 15m 20m 30m**

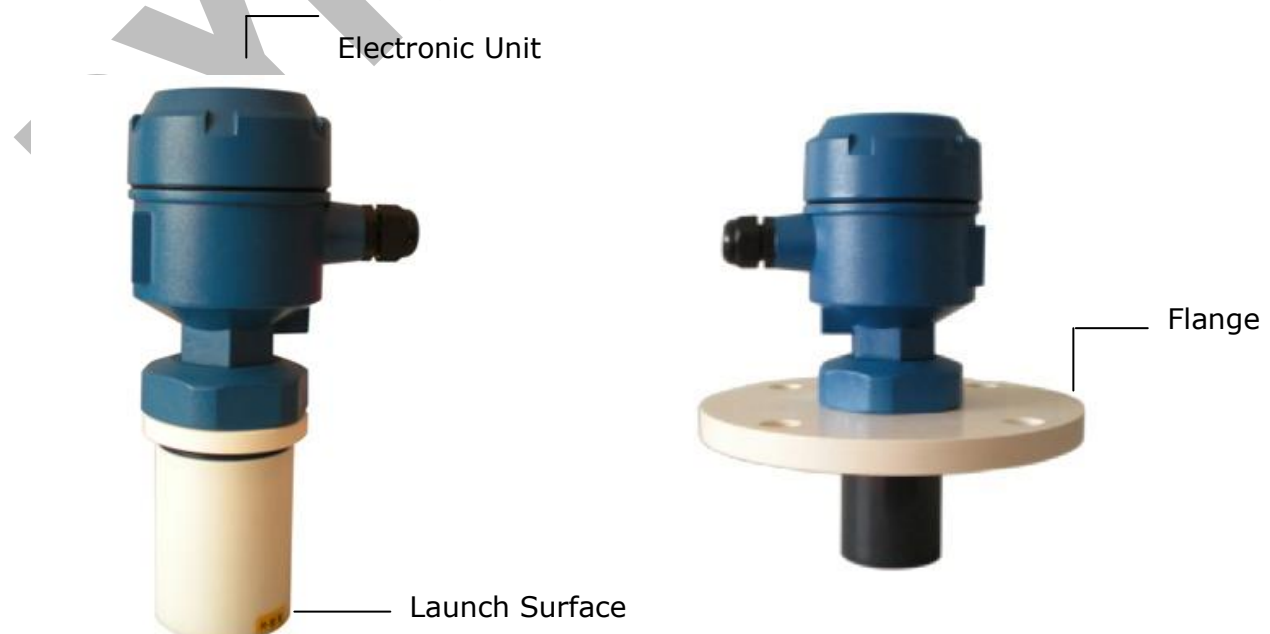

## 2. The combined type and sensor:



## TECHNOLOGICAL PRINCIPLE

The level meter is composed with the designed in the integrative ultrasonic wave sensor and electronic unit. The level meter installs on the top of the container, under the control of the electronic unit, the sensor launches a bunch of ultrasonic pulses to the things of tested. Sound wave is reflected by object surface; parts of reflected return waves echo are received and change into the electric signal. The time of launching ultrasonic wave to receiving it again is direct ratio to the distance of sensor to the things of tested. The electronic unit measures the time, and calculates out the distance examined according to the known velocity of sound. Then draw the location value of things through subtraction operation.

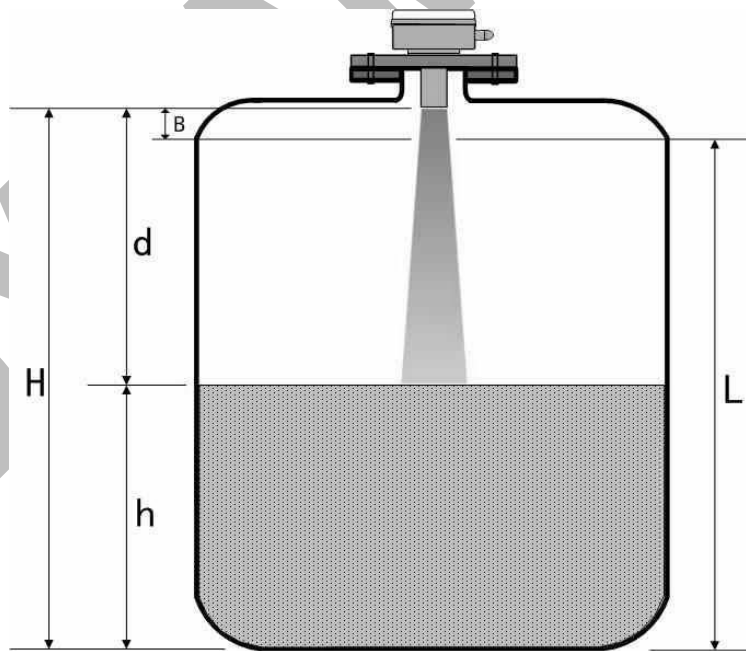

- B: Blind Space
- d: Empty Space
- h: Level
- H: Install Height
- L: Range

$$h = H - d$$

**Sketch Map of Level Measuring**

Ultrasonic waves spread speed among gas is influenced by gas temperature, when level meter works, it measures gas temperature needed, compensates for the velocity of sound, so as to ensure the precision of measuring. While level meter launches the ultrasonic pulse, it can't measure the return waves at the same time. One short distance downward from sensor is Blind Space. If the supreme thing location examined enters the blanking distance, the instrument can't measure correctly, then error. If needed, we can count the level meter and increase to install.

## Selection Table of DynaProbe Level Meter



<b>101DP Structure</b>	
101DP-1	Compact structure
101DP-2	Dividual structure
<b>Fixing</b>	
B	Standard Fixing
T	Non-Standard Fixing
<b>Wires system</b>	
1	3/4 wires
2	2 wires
<b>Sensor Material</b>	
V	PVC
T	PTFE
<b>PVC base</b>	
1	No Base
2	With base
<b>Approvals</b>	
N	Normal place
Ex	EX dIICT6
<b>Display</b>	
O	No display
M	With display
<b>Fluid</b>	
Y	Liquid level
L	Solid level
<b>Measuring range:m</b>	
D4	4
D6	6
D8	8
D10	10
D15	15
D20	20
D30	30
<b>Power supply</b>	
B	24VDC
D	220VAC
<b>Output</b>	
0	No
1	4-20mA
2	RS485
3	Modbus
4	Profibus
<b>Others</b>	
	remote control
	4pcs Relay
	6pcs Relay

**Explain:** 1. For two-wire system, the meter of 12m and 40 m range is not available.

2. For three-wire system, the meter of 40m range is not available.

3. For four-wire system, the meter of 10m range is not available.

4. For separate simplicity ones, the meter of 12m, 30m and 40 m range is not available.

5. For four -wire system with 24vdc power supply, the LED display will be available. The others will be of LCD display.

101DP	Intergrated structure			Dividual structure			Level difference	
Type	2 wires standard		3/4 wires popular		4 wires multifunction		Output	
					Standard		multifunction anti-interference level difference	
24VDC	*		*	*	*	*	*	*
220VAC		*	*	*	*	*	*	*
4-20mA	*	*	*	*	*	*	*	*
RS485 ModbusProfibus				*	*	*	+	*
2 wires	*							*
3 or 4 wires		*	*					*
upper and lower limit relay			*					*
2 pcs relay						*		*
4pcs relay						*	*	*
6pcs relay							*	*
Failure								*
2 points measurement						*		*
remote control						*		*
<b>Range (Base price)</b>								
D4-4m	*	*	*	*	*	*	*	*
D6-6m	*	*	*	*	*	*	*	*
D8-8m	*	*	*	*	*	*	*	*
D10-10m	*	*	*	*	*	*	*	*
D12-12m								*
D15-15m	*	*	*	*	*	*	*	*
D20-20m	*	*	*	*	*	*	*	*
D30-30m	*	*	*	*	*	*	*	*
<b>Option Part: (Base price)</b>								
DP4-Ex	*							*
DP8-Ex	*							*
DF4-Ex	*							*
DF8-Ex	*							*
<b>Adder</b>								
4pcs Relay						*	*	*
6pcs Relay							*	*
RS485				*	*			*
Modbus				*	*	*		*
Profibus				*	*	*		*
Remote-control						*		*
PVC Base	*	*	*	*	*	*	*	*
PTFE	*	*	*	*	*	*	*	*

### Remarks:

1. The file is valid up to Dec. 31, 2010.
2. For Dividual structure, standard cable is 10m, the longest is 1000m.
3. DP4-Ex, the sensor material is PVC;
4. DF4-Ex, the sensor material is PTFE and stainless steel drive pipe.

## TECHNOLOGICAL SPECIFICATION

<b>Measuring Range:</b>							
Liquid	4.00 m	6.00m	8.00m(A)	10.00m	15.00m	20.00m	30.00m
Solid			3.00m	4.00m	6.00m	10.00m	15.00m
<b>Blind Space:</b>							
Measuring Range	4m	6m	8m(A)	10m	15m	20m	30m
Blind Space	0.20 m	0.25m	0.30m	0.40m	0.60m	0.80m	1.20m
<b>Accuracy:</b>	0.2% Full Span (In air)						
<b>Resolution Ratio Shown:</b>							
Measuring Range: 4m 6m 8m:	1mm						
Measuring Range: 8.00m(A) 10m 15m 20m 30m:	1cm						
<b>Mode of Indication:</b>	4 Digit LCD						
<b>Output Current:</b>	4~20mA						
<b>Output Load:</b>	0~500Ω						
<b>Output Resolution Ratio:</b>	0.03% full span						
<b>Parameter Set Up:</b>	3 induction buttons						
<b>Temperature Range:</b>	(-40°C to 80°C)						
<b>Temperature Compensation:</b>	The whole range is automatic						
<b>Pressure Range:</b>	±0.1MP (press definitely)						
<b>Power Supply:</b>	DC24V ±20% 30mA						
<b>Cable Diameter:</b>	F6~F12mm						
<b>Single Wire Diameter:</b>	F0.5~F1.78mm						
<b>Cable Fix:</b>	PG13.5						
<b>Beam Angle:</b>	8°(3db) Measuring Range 4m 6m 8m						
	5°(3db) Measuring Range 8m(A) 10m 15m 20m 30m						
<b>Measure Cycle:</b>	1second						
<b>Crust Material:</b>	ABS						
<b>Sensor Material:</b>	PVC						
<b>Protect Grade:</b>	IP67						
<b>Mode Installation:</b>	Flange or the support						
<b>Flange Standard of Butt Joint:</b>							
<b>Measuring range 4m 6m 8m:</b>	Minimum DN65						
<b>Measuring range 8m(A) 10m:</b>	Minimum DN80						
<b>Measuring range 15m:</b>	Minimum DN150						
<b>Measuring range 15m 20m 30m:</b>	Minimum DN200						

## Drawings and Dimensions

The complete version---Metal material crust

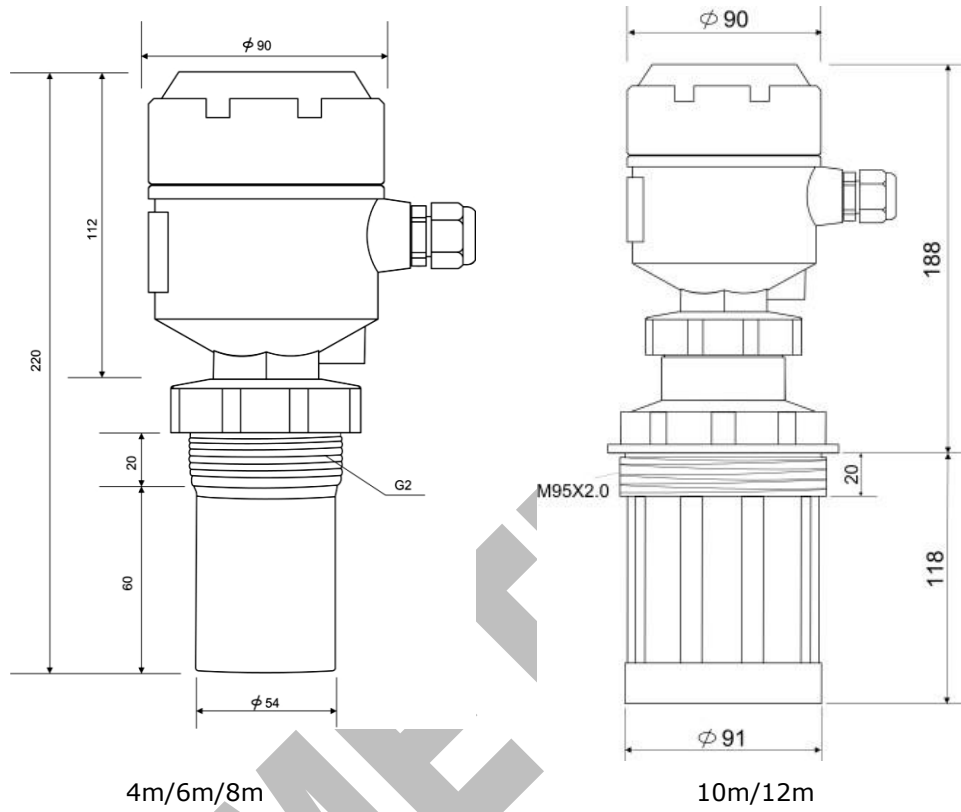

4m/6m/8m

10m/12m

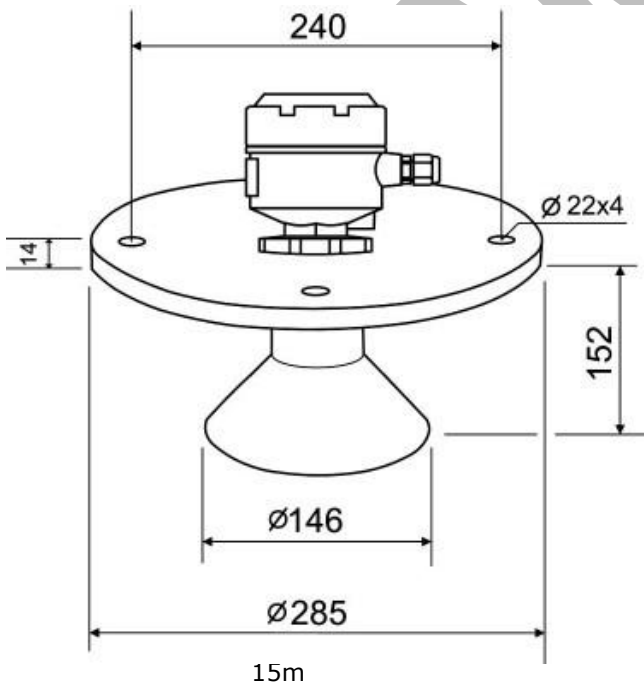

15m

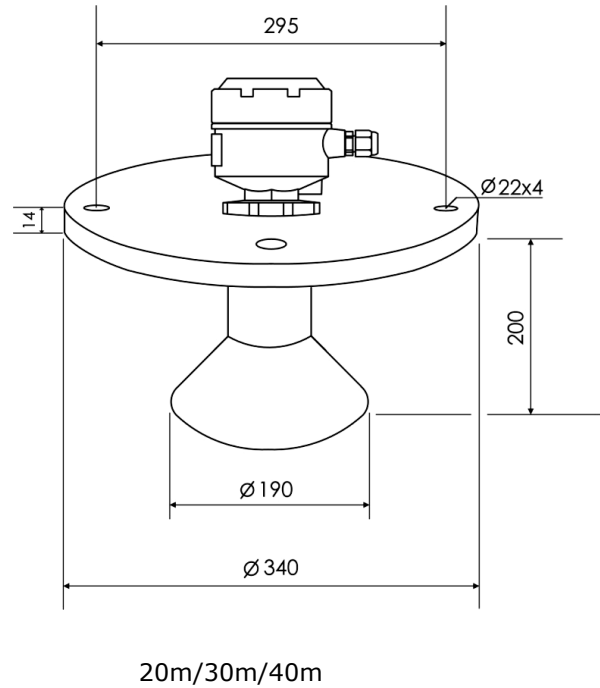

20m/30m/40m

**Combined version**  
**101 DP-F series**  
**The host**

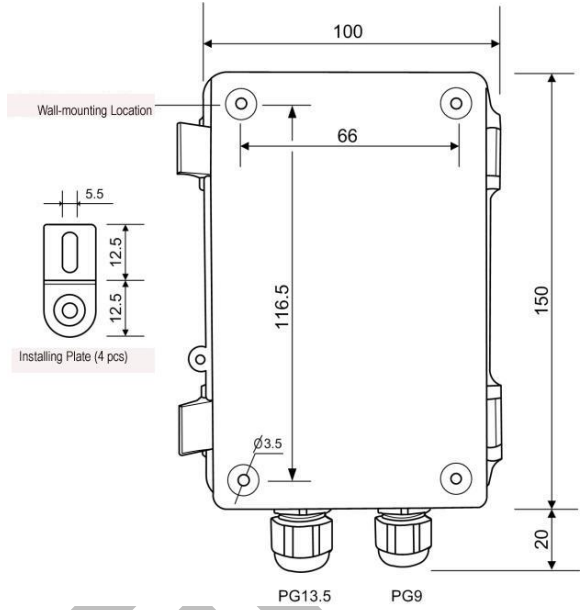
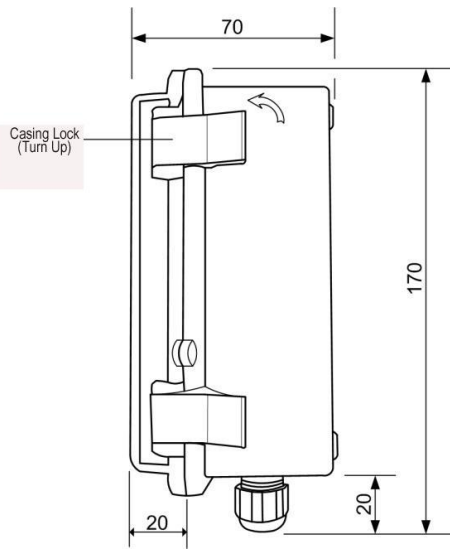

**The probe**

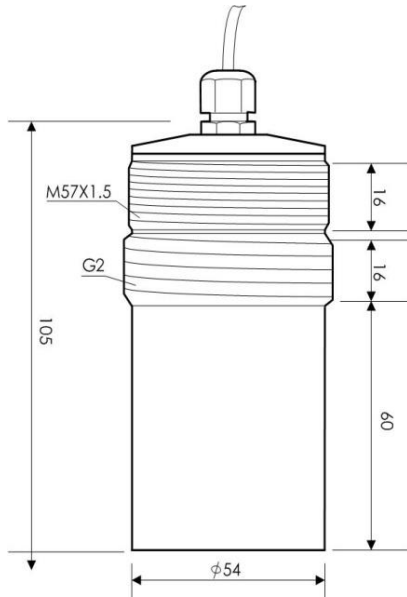

4m/6m/8m

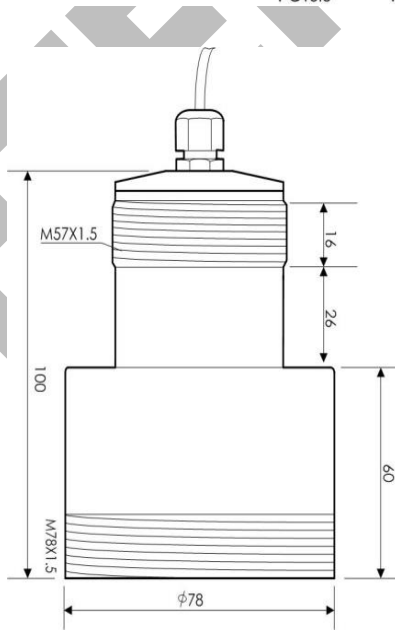

10m

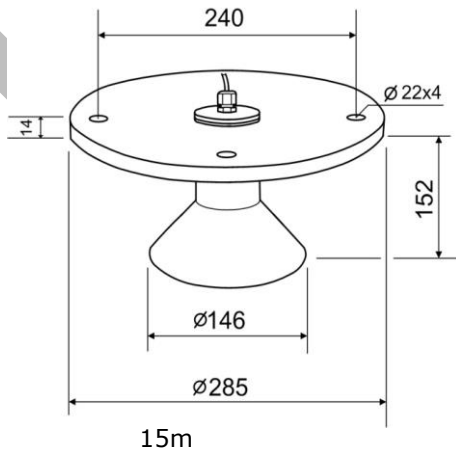

15m

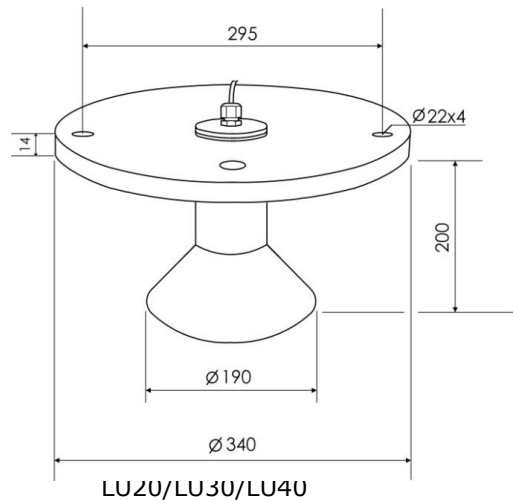

LU20/LU30/LU40

## Terminal Block Diagram

### Combined Type

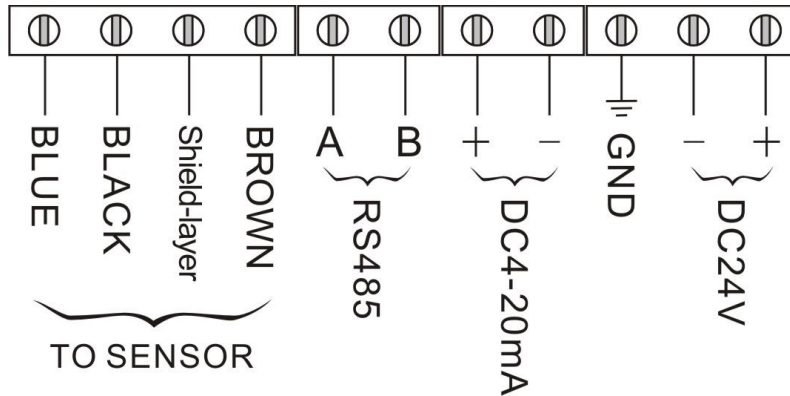

## How to choose separate ultrasonic level meter

### ◆ measuring range

Select model number according to actual range.

Select model number with bigger range if medium level fluctuates strongly.

The range of solid level is generally one-half to two-third of that of liquid.

### ◆ power supply

#### ● DC24V POWER SUPPLY:

1. For two-wire system, the power supply current should not be less than 30 mA.
2. For three-wire system, the power supply current should not be less than 60 mA.
3. For four-wire system, the power supply current should not be less than 80 mA.

#### ● 220VAC POWER SUPPLY:

Only for four-wire system, the power supply current should not be less than 50 mA.

### ◆ Mounting conditions for tank

#### ● closed tank

1. For range less than 8m, the size of orifice on tank should be more than that of DN65 flange;
2. For range of 10m and 12m, the size of orifice on tank should be more than that of DN80 flange;
3. For range of 15m, the size of orifice on tank should be more than that of DN150 flange;
4. For range of 20m, 30m and 40m, the size of orifice on tank should be more than that of DN200 flange;

#### ● open tank

1. For range less than 8m, the diameter of orifice on tank should be more than 65mm.
2. For range of 10m and 12m, the diameter of orifice on tank should be more than 80 and its thickness should be less than 15cm.;
3. For range of 15m, the diameter of orifice on tank should be more than that 150mm and its thickness should be less than 15cm.
4. For range of 20m, 30m and 40m, the diameter of orifice on tank should be more than 200mm and its thickness should be less than 20cm.



5.

- **open pond**

Fixing stand should be needed.

Open type pond son

Should adopt to add high gearing, keep sensor of the ultrasonic level meter forming frost or freezing.

- **tank**

When mounting flange is applied, means for keeping warm should be done.

If no means to warm, please order the meter with lengthened probe into inner of the tank.

**DYNAMETERS™**

**DYNAMETERS™**

**Dynameters Shanghai Co., Ltd**

No.751 Shulin Rd, Eastward New Area,  
Songjiang Industrial Zone,  
Shanghai 201611

Tel : (+86)21 6760 2289

Fax : (+86)21 6760 2287

E-mail: [info@dynameters.com](mailto:info@dynameters.com)

Web: [www.dynameters.com](http://www.dynameters.com)

**Solenvis**  
experts in **energy** metering

**Solenvis Limited,**

The Peacock Conservatory,  
Weir Bank,

Bray-on- Thames,

Berkshire. SL6 2ED United Kingdom

Tel 01628 762775

Fax 01628 762763

Email: [sales@solenvisflowmeters.com](mailto:sales@solenvisflowmeters.com)

Web: [www.solenvisflowmeters.com](http://www.solenvisflowmeters.com)