



Woltman Turbo - Water Meter Model WT II

A family of compact size Woltman water meters with field interchangeable lightweight measuring units.

Features

- High accuracy, low loss of head and high immunity against abrasive media in the water due to double magnetic coupling. This unique construction leaves only one moving element, the impeller, in contact with water. The next moving components, including the worm & worm wheel, are kept in a sealed, dry compartment and have no contact with any abrasive media present in the water.
- Tungsten carbide impeller shaft tips & bearings for negligible wear in Heavy Duty use are standard.
- A wide selection of sealed, magnetically coupled registers, adaptable to 2G and 3G technologies, as well as different electrical output versions, single or multiple, are available.
- Registers are: Stainless steel/glass encapsulated and guaranteed against fogging.

Applications

Water supply networks, agricultural application and industrial use

Available Sizes

2" -12" (50mm - 300mm)

Standards

ISO 4064, ANSI 150, EEC

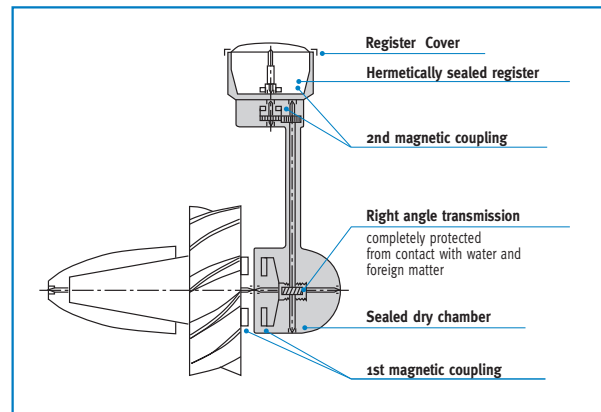

Technical Specifications

Maximum Working Pressure	Standard - 16 bar Upon request – 25 bar
Maximum Liquid Temperature	60°C
Body	Cast iron, polyester coated. Optional - bronze (AWWA standard)
Connection	Flanges according to ISO, BS 10, ANSI 150 or others



WT II type dial



► Woltman meters

└ WT II

- Irrigation & Agriculture
- Compound meters
- Fire Service meters
- Electrical Output

Performance data

Model WT II		Qmax Maximum flowrate (m ³ /h)	Qn ISO 4064 (m ³ /h)	Qn Nominal Flowrate (m ³ /h)	Qt Transitional Flowrate (m ³ /h)	Qmin Minimum Flowrate (m ³ /h)	Starting Flow (m ³ /h)	Maximum register capacity (m ³)	Smallest readable unit (liter)	Accuracy between Qmax & Qt	Accuracy between Qt & Qmin
Nominal Size											
mm	inch										
50	2	100	15	50	1	0.45	0.30	10 ⁶	1	±2%	±5%
65	2½	100	25	70	1.4	0.75	0.4	10 ⁶	1		
80	3	170	40	120	1.4	0.8	0.4	10 ⁶	1		
100	4	300	60	230	2	1.5	0.6	10 ⁷	10		
150	6	410	150	260	3.5	2.5	1.0	10 ⁷	10		
200	8	730	250	450	15	7	2	10 ⁸	100		
250	10	1400	400	750	13	10	6	10 ⁸	100		
300	12	2000	600	1000	40	11.5	7	10 ⁸	100		

Dimensions

Model	WT II								
Nominal size	(mm)	50	65	80	100	150	200	250	300
	(inch)	2	2½	3	4	6	8	10	12
L – Length (mm)		200	200	230	250	300	350	450	500
B – Width (mm)		165	185	200	200	283	340	406	460
H – Height (mm)		214	228	234	250	310	338	438	465
h – Height (mm)		70	84	90	106	130	158	258	330
Weight (kg)		12	13	15.5	19	35	47	75	95

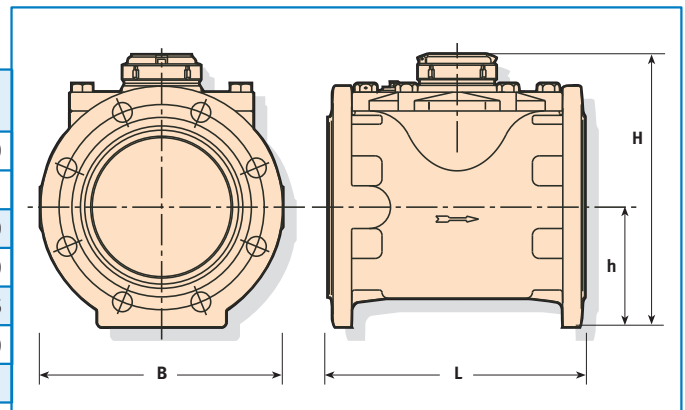

Flow Limit

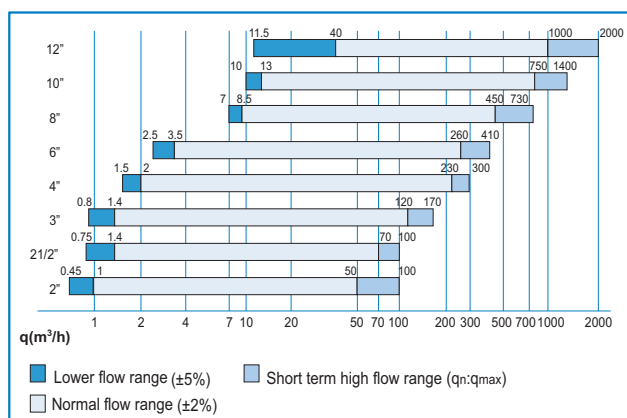

Head Loss Curve

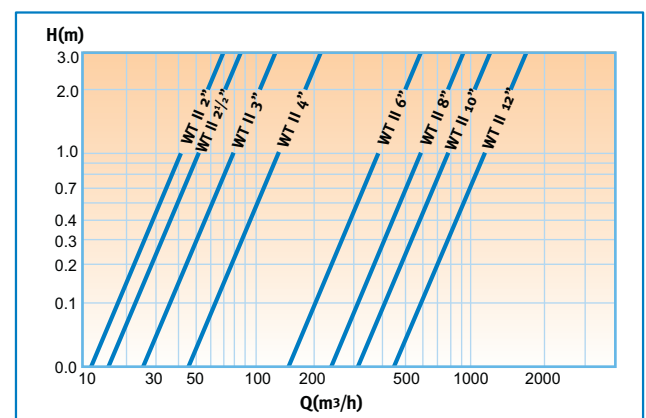

Installation Requirements

- The water meter may be installed in any position. For non-horizontal positions the flow shall be upwards.
- The meter shall be full of water while operating.
- Prior to installation of a meter, the pipeline shall be thoroughly flushed.
- Straight pipe section of the same diameter D as the meter, having length of 5D and 2D shall be installed upstream and downstream of the meter respectively.

